

First Grade

2025

Gustavo Rubino Ernesto

This book is divided into Epoches. There are six epoches, and it is up to the teacher to decide how long a Epochen should last. It is the authors opinion that each should last around 2 ½ to 3 weeks.

This book emphasizes the importance of extensive reading as a cornerstone of language acquisition. The mantra "read, read, read" underscores the belief in the critical role of reading for developing language proficiency. Reading provides learners with exposure to authentic language input, enabling them to acquire vocabulary, grammar, and language structures naturally and meaningfully.

Stephen Krashen's Input Hypothesis, a central theory in second language acquisition, posits that language acquisition occurs when learners are exposed to comprehensible input, which is language slightly beyond their current proficiency but still understandable with contextual clues. Krashen developed this hypothesis to explain how learners progress in their language abilities through exposure to language that is challenging yet accessible. Reading serves as a rich source of such input, allowing learners to encounter diverse vocabulary and grammatical structures in context, thus facilitating natural language acquisition.

Several benefits of extensive reading for language learners are highlighted. It aids vocabulary expansion by exposing learners to various words and phrases in different contexts and helps with grammar acquisition as learners intuitively grasp rules and structures through contextual encounters. Reading fosters fluency development by improving reading speed and automaticity, crucial for effective communication. Additionally, it enhances cultural awareness by exposing learners to different cultures and perspectives.

A supportive reading environment with access to a wide range of materials suited to learners' interests and proficiency levels is advocated. Teachers are encouraged to promote extensive reading through independent reading opportunities, varied reading material choices, and integrated reading activities in the curriculum. This approach underscores the power of reading in developing language proficiency in ESL and language learning contexts.

The concept of "optimal input" is introduced, involving language input slightly beyond learners' current proficiency but still comprehensible. Optimal input should be interesting, relevant, meaningful, and presented in a low-anxiety environment, incorporating a variety of language forms and structures consistently over time.

To apply optimal input in a first-grade classroom, teachers should ensure language input is comprehensible, using simple language, visual aids, and context clues. Content should be meaningful and relevant, reflecting students' interests and experiences. Lessons should include interactive and engaging activities, such as

group discussions, cooperative tasks, role-playing, and project-based learning. A supportive learning environment should be fostered, encouraging risk-taking and positive reinforcement. Instruction should be differentiated to meet diverse needs, with consistent exposure to language integrated across subjects and activities. Regular assessments and feedback should help students monitor progress and set learning goals.

Each class session is structured into four parts: singing, construction reading, book reading, and playing. Students are allowed three behavioral strikes during the first three parts; if they reach three strikes, they color a drawing. If not, they engage in free play. The book is organized into six epochs, each lasting two and half weeks.

First Epoch

Songs

GOD MADE THE SUN (stand up)

God made the sun,
God made the trees.
God made the mountains,
And God made me.
I thank you oh God,
For the sun and the trees,
For making the mountains,
And for making me.

THE EARTH LIES FIRM BENEATH MY FEET,

The sun shines bright above.
And here I stand,
So straight and strong,
All things to know and love.

DIALOGUE TIME

“How are you?”

“I am fine thanks, and you?”

What is this? (point to something in class) (start asking that on the third class)

What is that? (point to something in class) (start asking that on the third class)

What is this? (show a picture) (start asking that on the third class)

Is this a bench? (start asking that on the third class)

Is that an airplane? (start asking that on the third class)

May I go to the bathroom?

HEAD, SHOULDERS, KNEES, AND TOES, KNEES, AND TOES

Head, shoulders, knees, and toes, knees, and toes. And eyes and ears and mouth and nose. Head, shoulders, knees, and toes, knees, and toes.

WHAT'S YOUR FAVORITE (SEASON)

What's your favorite
What's your favorite season? season?
What's your favorite
What's your favorite season? season?
I like spring, I like spring
I like summer, I like summer
I like winter, I like winter
I like the fall, I like the fall
What's your favorite
What's your favorite season? season?
What's your favorite
What's your favorite season? season?

CLASS DIARY

Say a name and the student or students must reply:

I am here
He is not here
She is not here

MONTHS OF THE YEAR; WHAT MONTH IS TODAY? (Sit down)

January, February, March, April,

May, June, July, and August

September, October, November, December

These are the months of the year.

THE DAYS OF THE WEEK

Are seven in a row

Monday, Tuesday, Wednesday, Thursday, Friday, Saturday, Sunday

The days of the week

How quickly they go

If snowy or rainy

Or sunny or gay,

The days of the week

Dance quickly away

WHAT DAY IS TODAY?

Is today Tuesday?

Is today Friday?

WHAT MONTH IS IT?

Is it January? Is it September?

NUMBERS 1 TO 30

1 – 40 (second week)

1 – 50 (third week)

COLORS, COLORS

What's your favorite color?

Colors, colors,

What's your favorite color?

My favorite color's blue, I like blue, I like blue!

My favorite color's blue, I like blue, I like blue!

What's your favorite color?

Colors, colors,

What's your favorite color?

My favorite color's red, I like red, I like red!

My favorite color's red, I like red, I like red!

(CHORUS)

My favorite color's green, I like green, I like green!

My favorite color's green, I like green, I like green!

(CHORUS)

My favorite color's yellow, I like yellow, I like yellow!

My favorite color's yellow, I like yellow, I like yellow!

(CHORUS)

My favorite color's orange, I like orange, I like orange!

My favorite color's orange, I like orange, I like orange!

(CHORUS)

My favorite color's purple, I like purple, I like purple!

My favorite color's purple, I like purple, I like purple!

WHERE IS THUMBKIN? (Sit down)

Here I am, here I am.

How are you this morning? Very well, thank you.

Run away, run away.

Where is pointer, where is pointer?

Here I am, here I am.

How are you this morning? Very well, thank you.

Run away, run away.

Where is tall man, where is tall man?

Here I am, here I am.

How are you this morning? Very well, thank you.

Run away, run away.

Where is ring man, where is ring man?

Here I am, here I am.

How are you this morning? Very well, thank you.

Run away, run away.

Where is pinkie, where is pinkie?

Here I am, here I am.

How are you this morning? Very well, I thank you.

Run away, run away.

Where are all my fingers, where are all my fingers?

Here they are, here they are.

How are you this morning? Very well, we thank you.

Run away, run away.

OPEN THEM AND CLOSE THEM (stand up)

And lift them in the air
Open them and close them
And put them on your hair
Open them and close them
And give a little clap
Open them and close them
And put them on your lap

BODY PARTS

This is my head
These are my eyes
This is my nose
This is my hair
This is my mouth
These are my arms
These are my hands
This is my right hand
This is my left hand
These are my fingers
These are my legs
These are my feet
This is my right foot
This is my left foot
These are my toes

TEN LITTLE FINGERS

Ten little fingers standing straight, (Hold up both hands, with fingers straight up)

Ten little fingers open the gate, (Swivel wrists)

Ten little fingers make a ring, (Make fingers into a ring)

Ten little fingers bow to the king, (Bend fingers)

Ten little fingers dance all day, (Dance hands & fingers)

Ten little fingers hide away. (Hide hands behind back)

IF YOU ARE HAPPY AND YOU KNOW IT

If you're happy and you know it, **CLAP YOUR HANDS**

If you're happy and you know it, **STOMP YOUR FEET**

If you're happy and you know it, **SNAP YOUR FINGERS**

If you're happy and you know it, **SLAP YOUR TIGHTS**

If you're happy and you know it, **PAT YOUR HEAD**

If you're happy and you know it, **TURN AROUND**

EXERCISES TIME

UP

Down

Hands and Arms pointing to the right

Hands and Arms pointing to the left

In front of

Behind

On

Under

Between (3x)

SAYING GOODBYE

Bye, bye

See you tomorrow

See you on Monday

Constructions

First Week

book

notebook

eraser

pencil

I am here

He is not here

She is not here

This is a lamp

This is a bench

That is a window

That is the blackboard

Second Week

This is not a bench

These are not lamps

That is not a window

Those aren't blackboards

This is a foot

These are feet

This is a hand

These aren't two hands

This is a dog

These are five dogs

This is a cat

These are six cats

Third Week

I am in school

I am not in school

I was in school

I was not in school

You are in school

You are not in school

You were in school

You were not in school

He is in school

He is not in school

He was in school

He was not in school

Books

Mondays, Wednesdays, and Fridays

Spot Looks at Opposites

I Like Bugs

Spot says please

Tuesdays, and Thursdays

Brown bear brown bear what do you see?

Ducks go Vroom

Where's spot?

Second Epoche

Songs

GOD MADE THE SUN (stand up)

God made the sun,
God made the trees.
God made the mountains,
And God made me.
I thank you oh God,
For the sun and the trees,
For making the mountains,
And for making me.

THE EARTH LIES FIRM BENEATH MY FEET,

The sun shines bright above.
And here I stand,
So straight and strong,
All things to know and love.

DIALOGUE TIME

“How are you?”

“I am fine thanks, and you?”

“What's up?”

“Nothing much” “It's all good”

“How you doing?” “I'm good thanks, you?”

How do you say **May I go to the bathroom?** in German?

How do you say **book** in German? (first week)

How do you say **notebook** in German? (first week)

How do you say **eraser** in German? (first week)

How do you say **pencil** in German? (first week)

How do you say **I am here** in German? (first week)

How do you say **He is not here** in German? (first week)

How do you say **She is here** in German? (first week)

How do you say **This is a lamp** in German? (first week)

How do you say **This is a bench** in German? (first week)

How do you say **That's a window** in German? (first week)

How do you say **That is the blackboard** in German? (first week)

How do you say **This is not a bench** in German? (first week)

How do you say **These are not lamps** in German? (first week)

How do you say **That is not a window** in German? (first week)

How do you say **Those aren't blackboards** in German? (first week)

How do you say **This is a foot** in German? (second week)

How do you say **These are feet** in German? (second week)

How do you say **This is a hand** in German? (second week)

How do you say **These aren't two hands** in German? (second week)

How do you say **This is a dog** in German? (second week)

How do you say **These are five dogs** in German? (second week)

How do you say **This is a cat** in German? (second week)

How do you say **These are six cats** in German? (second week)

How do you say **I am in school** in German? (third week)

How do you say **I am not in school** in German? (third week)

How do you say **I was in school** in German? (third week)

How do you say **I was not in school** in German? (third week)

How do you say **You are in school** in German? (third week)

How do you say **You are not in school** in German? (third week)

How do you say **You were in school** in German? (third week)

How do you say **You were not in school** in German? (third week)

How do you say **He is in school** in German? (third week)

How do you say **He is not in school** in German? (third week)

How do you say **He was in school** in German? (third week)

How do you say **He was not in school** in German? (third week)

EXERCISES (sit down)

Up

Down

To the right (point both hands to the right)

To the left

In front of

Behind

On

Under

Between (3x)

VERBS (sit down) (in the middle of the second week ask the kids what these verbs mean in their native language)

I'm writing, I'm reading

You are having, you are doing

He is telling , he is talking, he is saying

She is coming, she is going

We are thinking, we are knowing

They are making, they are working, they are using

I'm standing, I'm sitting

You are looking, you are seeing, you are finding

She is getting, she is taking, she is giving

We are eating, we are drinking
I'm writing, I'm reading

NUMBERS 1 TO 60 (sit down)

1 – 70 (second week)

1 – 100 (third week)

MONTHS OF THE YEAR; WHAT MONTH IS TODAY? (Sit down)

January, February, March, April, (move your arm to the opposite side making
each month a wave)

May, June, July, and August

September, October, November, December (both hands move forward in a
wave)

These are the months of the year.

THE DAYS OF THE WEEK (sit down)

Are seven in a row

Monday, Tuesday, Wednesday, Thursday, Friday, Saturday, Sunday

The days of the week

How quickly they go

If snowy or rainy

Or sunny or gay,

The days of the week

Dance quickly away

WHAT DAY IS TODAY?

Is today Tuesday?

Is today Friday?

WHAT MONTH IS IT?

Is it January? Is it September?

CLASS DIARY

Say a name and the student or students must reply:

I am here

He is not here

She is not here

THE KEY OF THE KINGDOM (sit down)

This is the key of the kingdom

In that kingdom there is a city

In that city there is a street

In that street there is a lane

In that lane there is a yard

In that yard there is a house

In that house there is a room

In that room there is a bed

And ON that bed, there is a basket

A basket of sweet flowers

Of sweet flowers, of sweet flowers

A basket of sweet flowers

THE FARMER IS IN THE DEN

... The **farmer's** in the **den**

The farmer's in the den

Hey-ho the dairy-oh

The farmer's in the den
... The **farmer** wants a **wife**
The farmer wants a wife
Hey-ho the dairy-oh
The farmer wants a wife
... The **wife** wants a **child**
The wife wants a child
Hey-ho the dairy-oh
The wife wants a child
... The **child** wants a **dog**
The child wants a dog
Hey-ho the dairy-oh
The child wants a dog
... The **dog** wants a **bone**
The dog wants a bone
Hey-ho the dairy-oh
The dog wants a bone

OLD MACDONALD HAD A FARM

E-I-E-I-O

And on his farm, he had a **COW**

E-I-E-I-O

With a **MOO MOO** here

And a **MOO MOO** there

Here a **MOO**, there a **MOO**

Everywhere a **MOO MOO**

Old MacDonald had a farm. E-I-E-I-O

Old MACDONALD had a farm. E-I-E-I-O

And on his farm, he had a **PIG**

E-I-E-I-O

With an **OINK OINK** here

And an **OINK OINK** there

Here an **OINK**, there a **OINK**

Everywhere an **OINK OINK**

Old MacDonald had a farm. E-I-E-I-O

Old MACDONALD had a farm. E-I-E-I-O

And on his farm, he had a **CAT**

E-I-E-I-O

With a **MEW MEW** here

And a **MEW MEW** there

Here a **MEW**, there a **MEW**

Everywhere a **MEW MEW**

Old MacDonald had a farm. E-I-E-I-O

Old MACDONALD had a farm. E-I-E-I-O

And on his farm, he had a **HORSE**

E-I-E-I-O

With a **NEIGH NEIGH** here

And a **NEIGH NEIGH** there

Here a **NEIGH**, there a **NEIGH**

Everywhere a **NEIGH NEIGH**

Old MacDonald had a farm. E-I-E-I-O

Old MACDONALD had a farm. E-I-E-I-O

And on his farm, he had a **DOG**

E-I-E-I-O

With a **AUA AUA** here

And a **AUA AUA** there

Here a **AUA**, there a **AUA**

Everywhere a **AUA AUA**

Old MacDonald had a farm E-I-E-I-O

Old MACDONALD had a farm. E-I-E-I-O

And on his farm, he had some **CHICKENS**

E-I-E-I-O

With a **CLUCK CLUCK** here

And a **CLUCK CLUCK** there

Here a **CLUCK**, there a **CLUCK**

Everywhere a **CLUCK CLUCK**

ALLIGATOR, GIRAFFE, MONKEY, BIRD, HIPOPPOTAMUS, BULL (second week)

ZEBRA, BEAR, SHEEP, WOLF, DUCK, RABBIT, SNAKE, LION, ELEPHANT, TURTLE (third week)

ADJECTIVES

This big, this is small,

That is beautiful, that is ugly,

This is new, this is old

That is great, this is little

This is high, this is low

This is different, this is the same

That is large, that is small,

This is the best; this is the worst

That is long, that is short

This is real, this is false

OPEN THEM AND CLOSE THEM (stand up)

And lift them in the air
Open them and close them
And put them on your hair
Open them and close them
And give a little clap
Open them and close them
And put them on your lap

THE FOREST

The forest is the town of trees
Where they live quiet at their ease
With their neighbors at their side
Just as we in cities wide

TWO LITTLE EYES TO LOOK AROUND (sit down)

Two little ears to hear each sound,
One little nose to smell what's sweet,
One little mouth that likes to eat

TEN LITTLE FINGERS

Ten little fingers standing straight, *(Hold up both hands, with fingers straight up)*
Ten little fingers open the gate, *(Swivel wrists)*
Ten little fingers make a ring, *(Make fingers into a ring)*
Ten little fingers bow to the king, *(Bend fingers)*
Ten little fingers dance all day, *(Dance hands & fingers)*
Ten little fingers hide away. *(Hide hands behind back)*

ROW, ROW, ROW YOUR BOAT

Gently down the stream
Merrily, merrily, merrily, merrily
Life is but a dream
Row, row, row your boat

IT'S A SMALL WORLD

It's a world of laughter
A world of tears
It's a world of hopes
And a world of fears
There's so much that we share
That it's time we're aware
It's a small world after all
It's a small world after all
It's a small world after all
It's a small world after all
It's a small, small world

SAYING GOODBYE

Bye, bye
See you tomorrow
See you on Monday

Constructions

First Week

We are in school

We are not in school

We were in school

We were not in school

They are in school

They aren't in school

They were in school

They weren't in school

I do my homework every day

I don't do my homework every day

I did my homework last week

I didn't do my homework last week

Second Week

You do your homework every day

You don't do your homework every day

You did your homework last week

You didn't do your homework last week

She does her homework every day

She doesn't do her homework every day

She did her homework last week

She didn't do her homework last week

We do our homework every day

We don't do our homework every day

We did our homework last week

We didn't do our homework last week

Third Week

I have time

I don't have time

I had time

I didn't have time

You have a bad job

You don't have a bad job

You had a good life

You didn't have a good life

He has a big family

He doesn't have a big family

He had a small family

He didn't have a small family

Books

Mondays, Wednesdays, and Fridays

Polar Bear, Polar Bear, What do you hear?

Polar Bear Babies

Big Shark, Little Shark Go to School

Watch Your Step, Mr. Rabbit! (Step into Reading

Tuesdays, and Thursdays

From head to toe

Dragon Egg

Spot goes to school

Third Epoche

Songs

GOD MADE THE SUN (stand up)

God made the sun,
God made the trees.
God made the mountains,
And God made me.
I thank you oh God,
For the sun and the trees,
For making the mountains,
And for making me.

THE EARTH LIES FIRM BENEATH MY FEET,

The sun shines bright above.
And here I stand,
So straight and strong,
All things to know and love.

DIALOGUE TIME

“How are you?”

“I am fine thanks, and you?”

“What's up?”

“Nothing much” “It's all good”

How do you say **We are in school** in German? (first week)

How do you say **We are not in school** in German? (first week)

How do you say **We were in school** in German? (first week)

How do you say **We were not in school** in German? (first week)

How do you say **They are in school** in German? (first week)

How do you say **They aren't in school** in German? (first week)

How do you say **They were in school** in German? (first week)

How do you say **They weren't in school** in German? (first week)

How do you say **I do my homework every day** in German? (first week)

How do you say **I don't do my homework every day** in German? (first week)

How do you say **I did my homework last week** in German? (first week)

How do you say **I didn't do my homework last week** in German? (first week)

How do you say **You do your homework every day** in German? (second week)

How do you say **You don't do your homework every day** in German? (second week)

How do you say **You did your homework last week** in German? (second week)

How do you say **You didn't do your homework last week** in German? (second week)

How do you say **She does her homework every day** in German? (second week)

How do you say **She doesn't do her homework every day** in German? (second week)

How do you say **She did her homework last week** in German? (second week)

How do you say **She didn't do her homework last week** in German? (second week)

How do you say **We do our homework every day** in German? (second week)

How do you say **We don't do our homework every day** in German? (second week)

How do you say **We did our homework last week** in German? (second week)

How do you say **We didn't do our homework last week** in German? (second week)

How do you say **I have time** in German? (third week)

How do you say **I don't have time** in German? (third week)

How do you say **I had time** in German? (third week)

How do you say **I didn't have time** in German? (third week)

How do you say **You have a bad job** in German? (third week)

How do you say **You don't have a bad job** in German? (third week)

How do you say **You had a good life** in German? (third week)

How do you say **You didn't have a good life** in German? (third week)

How do you say **He has a big family** in German? (third week)

How do you say **He doesn't have a big family** in German? (third week)

How do you say **He had a small family** in German? (third week)

How do you say **He didn't have a small family** in German? (third week)

VERBS IN THE PAST (sit down)

I stood, I sat

I wrote, I read

You had, You did

He told , He talked, He said

She came, She went

We thought, We knew

They made, They worked, They used

You looked, you saw, You found

She got it, she took it, she gave it

We ate, We drank

I stood, I sat

I wrote, I read

FRUITS

At times I want an apple
Sometimes I want some grapes
Some days, I'm feeling hungry
And then I want to eat them all
Sometimes I want a banana
Sometimes I want a pear
Some days, I'm feeling hungry
And then I want to eat them all
At time I want an orange
Sometimes a watermelon
Some days, I'm feeling hungry
And then I want to eat them all

A, B, C

CLASS DIARY

Say a name and the student or students must reply:

I am here

He is not here

She is not here

VEGETABLES

Let's chop some carrots, **carrots**

Na na na

Let's chop some cabbage, **cabbage**

Na na na

Let's chop some broccoli, **broccoli**

Na na na

Some vegetables for you and me

Carrots, cabbage, broccoli 2x

Some vegetables for you and me

Let's chop some garlic, **garlic**

Na na na

Let's chop some onions, **onions**

Na na na

Let's chop some leek, **leek**

Na na na

Some vegetables for you and me

Garlic, onion, leek 2x

Some vegetables for you and me

EXERCISES

Up

Down

Right

In front of

Behind

Between (3x)

Under

On

To the right

To the left

AT THE ZOO by William Makepeace Thackeray

First, I saw the white bear, then I saw the black.

Then I saw the camel with a hump upon his back.

Then I saw the grey wolf, with mutton in his maw.

Then I saw the elephant waving his trunk.

Then I saw the monkeys – mercy, how unpleasantly the smell

WANTS

I want strawberries, I want marshmallows

I want an apple, I want a banana

I want pizza, I want bread

I want a carrot, I want spaghetti

NUMBERS 1 TO 100

100 to 200

200, 300, 400 ... 1000

1000 to 10.000

10.000 to 100.000

100.000 to 1.000.000

MONTHS OF THE YEAR; WHAT MONTH IS TODAY? (Sit down)

January, February, March, April,

May, June, July, and August

September, October, November, December

These are the months of the year.

SAYING NO!

I don't like the night

You don't like the city

He doesn't like the game

She doesn't like the house

We don't like the team

Because they're too bad

And they,

They don't like anything at all

HE LOVES THE OCEAN

He likes the ocean

He loves the sky

She likes to travel

She loves to fly

He likes the country

He loves the clouds

She likes the city

She loves the crowds

He likes the mountains

He loves to walk

She likes the phone

She loves to talk

ROW, ROW, ROW YOUR BOAT

Gently down the stream

Merrily, merrily, merrily, merrily

Life is but a dream

Row, row, row your boat

SAYING GOODBYE

Good-bye Mr. Ernesto

Constructions

First Week

She has a little house

She doesn't have a little house

She had a long night

She didn't have a long night

We have different friends

We don't have different friends

We had different books

We didn't have different books

They have an important question

They don't have an important question

They had a game last month

They didn't have a game last month

Second Week

I am going home

I went home

They are saying bad things about you

They said bad things about you

He makes good things

He made good things

We will get new things this year

We got new things last year

They think that you are great

They thought that you were great

He can speak English

He could speak English

Third Week

The woman can see the way to her house

The woman saw the way to her house

I know about the world

I knew about the world

There will be a new day

I will be a new man

She would do that

She wouldn't do that

He comes home late every night

He came late last night

She is taking the man and the woman to the big park

She took the man and the woman to the big park

We want a big pizza

We wanted a big pizza

He could come to school

He couldn't come to school

Books

Mondays, Wednesdays, and Fridays

I like stars

Too Many Cats

Brown owl

Tuesdays, and Thursdays

Panda Bear, Panda Bear, What do you see?

Find Spot at the Zoo

Go, Go, Planes!

Bear Hugs

Fourth Epoche

Songs

GOD MADE THE SUN (stand up)

God made the sun,
God made the trees.
God made the mountains,
And God made me.
I thank you oh God,
For the sun and the trees,
For making the mountains,
And for making me.

THE EARTH LIES FIRM BENEATH MY FEET,

The sun shines bright above.
And here I stand,
So straight and strong,
All things to know and love.

DIALOGUE TIME

“How are you?”

“I am fine thanks, and you?”

“What's up?”

“Nothing much” “It's all good”

FIRST WEEK

How do you say **She has a little house** in your L1? (first week)

How do you say **She doesn't have a little house** in German? (first week)

How do you say **She had a long night** in German? (first week)

How do you say **She didn't have a long night** in German? (first week)

How do you say **We have different friends** in German? (first week)

How do you say **We don't have different friends** in German? (first week)

How do you say **We had different books** in German? (first week)

How do you say **We didn't have different books** in German? (first week)

How do you say **They have an important question** in German? (first week)

How do you say **They don't have an important question** in German? (first week)

How do you say **They had a game last month** in German? (first week)

How do you say **They didn't have a game last month** in German? (first week)

SECOND WEEK

How do you say **I am going home** in German? (second week)

How do you say **I went home** in German? (second week)

How do you say **They are saying bad things about you** in German? (second week)

How do you say **They said bad things about you** in German? (second week)

How do you say **He makes good things** in German? (second week)

How do you say **He made good things** in German? (second week)

How do you say **We will get new things this year** in German? (second week)

How do you say **We got new things last year** in German? (second week)

How do you say **They think that you are great** in German? (second week)

How do you say **They thought that you were great** in German? (second week)

How do you say **He can speak English** in German? (second week)

How do you say **He could speak English** in German? (second week)

THIRD WEEK

How do you say **The woman can see the way to her house** in German? (third week)

How do you say **The woman saw the way to her house** in German? (third week)

How do you say **I know about the world** in German? (third week)

How do you say **I knew about the world** in German? (third week)

How do you say **There will be a new day** in German? (third week)

How do you say **I will be a new man** in German? (third week)

How do you say **She would do that** in German? (third week)

How do you say **She wouldn't do that** in German? (third week)

How do you say **He comes home late every night** in German? (third week)

How do you say **He came late last night** in German? (third week)

How do you say **She is taking the man and the woman to the big park** in German? (third week)

How do you say **She took the man and the woman to the big park** in German? (third week)

How do you say **We want a big pizza** in German? (third week)

How do you say **We wanted a big pizza** in German? (third week)

How do you say **He could come to school** in German? (third week)

SAY, EAT, BRAKE, TAKE, SPEAK, WRITE, DANCE, FLY, THINK, FEEL

Say, said stop on red

Eat, ate don't be late

Brake, broke have a coke

Take, took learn to cook,

Speak, spoke tell a joke

Write, wrote get off the boat

Dance, danced, take a chance

Fly, flew, skies so blue

Think, thought, lessons are taught

Feel, felt, every emotion dealt

THE MUFFIN MAN

Have you seen the muffin man,
The muffin man, the muffin man?
Have you seen the muffin man?
Who lives in Drury Lane?

FROM WIBBLETON TO WOBBLETON IS FIFTEEN MILES,

From Wobbleton to Wibbleton is fifteen miles,
From Wibbleton to Wobbleton, from Wobbleton to Wibbleton
From Wibbleton to Wobbleton is fifteen miles.

CLASS DIARY

Say a name and the student or students must reply:

I am here

He is not here

She is not here

LONDON BRIDGE IS FALLING DOWN

London bridge is falling down, falling down, falling down,
London Bridge is falling down,
My fair lady
Take a key and lock her up
Lock her up, lock her up
Take a key and lock her up
My fair Lady
Build it up with gold and silver
Gold and silver, gold and silver

Build it up with gold and silver

My fair Lady

Gold and Silver I have none

I have none, I have none

Gold and Silver I have none

My fair Lady

Build it up with Pins and Needles

Pins and Needles, Pins and Needles

Build it up with Pins and Needles

My fair Lady

SAYING NO!

I don't like the night

You don't like the house

He doesn't like the game

She doesn't like the city

We don't like team

Because they're too bad

And they?

They don't like

Anything at all!!

OH! SUSANNA

Oh, I come from Alabam

With my banjo on my knee

I'm going to Louisian

My true love for to see

It rained all night the day I left

The weather it was dry
The sun so hot, I froze to death
Susann', don't you cry
Oh, Susann
Don't you cry for me
For I come from Alabam
With my banjo on my knee
Oh, Susann
Don't you cry for me
For I come from Alabam
With my banjo on my knee

I HAVE HEARD A MOTHER BIRD

Singing in the rain
Telling all her little ones
Spring has come again!
I have seen a wave of green
Down a lovely lane
Making all the hedges glad
Spring has come again!

WHAT COLORS?

What colors, what colors do you like?
What colors do you like?
I like blue sky
I like green grass
I like purple butterflies
If you should ask

I like yellow daisies, red daisies too
Pink and orange sunsets
Watching them with you
I like white – snowy white
The black of the night
I like the brown of the earth in the ground

THE COW by Robert Louis Stevenson

The friendly cow, all red and white,
I love with all my heart:
She gives me cream with all her might,
To eat with apple tart.
She wanders here and there,
All in the pleasant open air,
In the pleasant light of day.
And blown by all the winds that pass
She walks among the meadow grass

TWINKLE, TWINKLE, LITTLE STAR

How I wonder what you are!
Up above the world so high,
Like a diamond in the sky.

SAYING GOODBYE

Bye, bye
See you tomorrow
See you on Monday

Constructions

First Week

They are looking at the child

They looked at the child

I use an old and dirty fork everyday

I used an old and dirty fork

I tell stories all the time

I told stories all the time

I will find the president

I found the president

The teacher is giving activities to the students

The teacher gave activities to the students

Where do you need to go?

I needed the toy yesterday

Second Week

It should be easy

She should have called.

His friend works for a book company

His friend worked for a book company

I always try to find the best words

I tried to find the best words

They let him win

Did you call her late at night?

I called her last night

This may help you!

What do you mean?

I meant to say yes

How are you feeling?

He felt sick last week

Third Week

She asked me about Brazilian history

We were just talking about Brazil

We talked about Brazil

Can you keep the dog outside, please?

You kept the dog outside

I'll be leaving at five o'clock tomorrow

I left at five o'clock yesterday

She put her bag on the table

She likes your eyes

She liked your eyes

He helps his mother

He helped his mother

I start reading a book

I started reading a book yesterday

Books

Mondays, Wednesdays, and Fridays

Spot Bakes a Cake

The Pup Speaks Up

Sleepy Dog

Tuesdays, and Thursdays

I am Dog

The Color Monster

Find Spot at the Library: A Lift-The-Flap Book

Books to be copied and read by the
kids in class

Polar Bear Babies
Big Shark, Little Shark Go to School
Watch Your Step, Mr. Rabbit!

Fifth Epoche

Songs

GOD MADE THE SUN (stand up)

God made the sun,
God made the trees.
God made the mountains,
And God made me.
I thank you oh God,
For the sun and the trees,
For making the mountains,
And for making me.

THE EARTH LIES FIRM BENEATH MY FEET,

The sun shines bright above.
And here I stand,
So straight and strong,
All things to know and love.

DIALOGUE TIME

“How are you?”

“I am fine thanks, and you?”

“What’s up?”

“Nothing much” “It’s all good”

How do you say **They are looking at the child** in German? (first week)

How do you say **They looked at the child** in German? (first week)

How do you say **I use and old and dirty fork everyday** in German? (first week)

How do you say **I used an old and dirty fork** in German? (first week)

How do you say **I tell stories all the time** in German? (first week)

How do you say **I told stories all the time** in German? (first week)

How do you say **I will find the president** in German? (first week)

How do you say **I found the president** in German? (first week)

How do you say **The teacher is giving activities to the students** in German? (first week)

How do you say **The teacher gave activities to the students** in German? (first week)

How do you say **Where do you need to go?** in German? (first week)

How do you say **I needed the toy yesterday** in German? (first week)

How do you say **It should be easy** in German? (second week)

How do you say **She should have called** in German? (second week)

How do you say **His friend works for a book company** in German? (second week)

How do you say **His friend worked for a book company** in German? (second week)

How do you say **I always try to find the best words** in German? (second week)

How do you say **I tried to find the best words** in German? (second week)

How do you say **They let him win** in German? (second week)

How do you say **Did you call her late at night?** in German? (second week)

How do you say **I called her last night** in German? (second week)

How do you say **This may help you!** in German? (second week)

How do you say **What do you mean?** in German? (second week)

How do you say **I meant to say yes** in German? (second week)

How do you say **How are you feeling?** in German? (second week)

How do you say **He felt sick last week** in German? (second week)

How do you say **She asked me about Brazilian history** in German? (third week)

How do you say **We were just talking about Brazil** in German? (third week)

How do you say **We talked about Brazil** in German? (third week)

How do you say **Can you keep the dog outside, please?** in German? (third week)

How do you say **You kept the dog outside** in German? (third week)

How do you say **I'll be leaving at five o'clock tomorrow** in German? (third week)

How do you say **I left at five o'clock yesterday** in German? (third week)

How do you say **She put her bag on the table** in German? (third week)

How do you say **She likes your eyes** in German? (third week)

How do you say **She liked your eyes** in German? (third week)

How do you say **He helps his mother** in German? (third week)

How do you say **He helped his mother** in German? (third week)

How do you say **I start reading a book** in German? (third week)

How do you say **I started reading a book yesterday** in German? (third week)

BE/HAVE/MAKE/CONQUER/KNOW/SAY/GET/THINK/SEE/GO/WANT/LIVE

In moments, be so glad,
All the good, and bad we've had.
Do what makes your heart feel light,
Conquer sad, with all your might.
Know the strength you hold inside,
Say sweet words, no need to hide.
Get through the tide that tries,
Think of the world with wide-open eyes.
See the beauty, stories unfold,
Go where adventures are boldly told.
Want the love that's warm and bold,
Live a tale, forever retold.

I HAVE A LITTLE HOUSE

I have a little house,
With new windows and an old door,
Two small chimneys on the top,
And a beautiful plot of grass before.

I have a little house,
With curtains and a blind,
Two small chimneys on the top,
And a plot of grass behind.

I have a little house,
Where I can go in and out,
Two small chimneys on the top,
And a garden all about.

CLASS DIARY

Say a name and the student or students must reply:

I am here.

He is not here.

She is not here.

THE COW by Robert Louis Stevenson

The friendly cow, all red and white,
I love with all my heart:
She gives me cream with all her might,
To eat with apple tart.
She wanders here and there,
All in the pleasant open air,
In the pleasant light of day.

And blown by all the winds that pass
She walks among the meadow grass

THE WHEELS ON THE BUS

The WHEELS on the bus go round and round
The WIPERS on the bus go "SWISH, swish, swish,
The DOOR on the bus goes OPEN and SHUT
The HORN on the bus goes "BEEP, beep, beep
The DIESEL on the bus goes "GLUG, glug, glug
The BRAKE on the bus goes "SCREECH, screech, screech!
The PEOPLE on the bus goes "CHATTER, chatter, chatter!
The MOMMY on the bus goes "SHUSH, shush, shush!
The BABY on the bus goes "WAH, wah, wah!
The wheels on the bus go round and round
Round and round, round, and round
The wheels on the bus go round and round
All day long.

WHEN I WAS ONE by A.A. Milne (adapted)

When I was one,
I had just begun.
When I was two,
I was nearly new.
When I was three,
I was hardly me.
When I was four,
I want so much more.
When I was five,

I was just alive.
When I was six,
I just ate chips
And now that I am seven,
I am in heaven

SAYING GOODBYE

Bye, bye
See you tomorrow
See you on Monday

Constructions

First Week

I will become someone better
I became a better person
That happens everyday
That happened yesterday
Show this man the door
He showed me the road
The children seem quite tired
The children seemed quite tired
I might come and visit you next year
My grandfather can't hear
She heard a noise outside.

Second Week

I believe she's arriving tomorrow.
She believed that it was wrong.
The children are playing with their new toys
The children played with their new toys
She is turning her face
She turned her face
He runs every evening
He ran yesterday
I live in a small village
I lived in a small village
She writes to her mother every week
She wrote to her mother last year

Third Week

She brings her dog to work every day

She brought her dog to work yesterday

They often move their furniture

They moved their furniture yesterday

I must get some sleep.

You mustn't do that

What time does the concert begin?

The concert began at nine o'clock

I love this book

He loved that book

Can you hold the door?

I held the door for him

Books

Mondays

Mouse paint

My five senses

Tuesdays

Find Spot at the museum.

Jack and Jill and Big Dog Bill Go Up the Hill

Wednesdays

Duck! Rabbit!

A color of his own

Thursdays

Mouse paint

My five senses

Fridays

Find Spot at the museum.

Jack and Jill and Big Dog Bill Go Up the Hill

Mondays

Duck! Rabbit!

A color of his own

Books to be copied and read by the
kids in class

Dragon Egg

Brown Owl

The Worst Helper Ever

Sixth Epoche

Songs

GOD MADE THE SUN (stand up)

God made the sun,
God made the trees.
God made the mountains,
And God made me.
I thank you oh God,
For the sun and the trees,
For making the mountains,
And for making me.

THE EARTH LIES FIRM BENEATH MY FEET,

The sun shines bright above.
And here I stand,
So straight and strong,
All things to know and love.

DIALOGUE TIME

“How are you?”

“I am fine thanks, and you?”

“What's up?”

“Nothing much” “It's all good”

I will become someone better

How do you say **I will become someone better** in German? (first week)

How do you say **I became a better person** in German? (first week)

How do you say **That happens everyday** in German? (first week)

How do you say **That happened yesterday** in German? (first week)

How do you say **Show this man the door** in German? (first week)

How do you say **He showed me the road** in German? (first week)

How do you say **The children seem quite tired** in German? (first week)

How do you say **The children seemed quite tired** in German? (first week)

How do you say **I might come and visit you next year** in German? ((first week)

How do you say **My grandfather can't hear** in German? (first week)

How do you say **She heard a noise outside** in German? (first week)

How do you say **I believe she's arriving tomorrow** in German? (second week)

How do you say **She believed that it was wrong** in German? (second week)

How do you say **The children are playing with their new toys** in German? (second week)

How do you say **The children played with their new toys** in German? (second week)

How do you say **She is turning her face** in German? (second week)

How do you say **She turned her face** in German? (second week)

How do you say **He runs every evening** in German? (second week)

How do you say **He ran yesterday** in German? (second week)

How do you say **I live in a small village** in German? (second week)

How do you say **I lived in a small village** in German? (second week)

How do you say **She writes to her mother every week** in German? (second week)

How do you say **She wrote to her mother last year** in German? (second week)

How do you say **She brings her dog to work every day** in German? (third week)

How do you say **She brought her dog to work yesterday** in German? (third week)

How do you say **They often move their furniture** in German? (third week)

How do you say **They moved their furniture yesterday** in German? (third week)

How do you say **I must get some sleep** in German? (third week)

How do you say **You mustn't do that** in German? (third week)

How do you say **What time does the concert begin?** in German? (third week)

How do you say **The concert began at nine o'clock** in German? (third week)

How do you say **I love this book** in German? (third week)

How do you say **He loved that book** in German? (third week)

How do you say **Can you hold the door?** in German? (third week)

How do you say **I held the door for him** in German? (third week)

BE/HAVE/MAKE/CONQUER/KNOW/SAY/GET/THINK/SEE/GO/WANT/LIVE

In moments, be so glad,
All the good, and bad we've had.
Do what makes your heart feel light,
Conquer sad, with all your might.
Know the strength you hold inside,
Say sweet words, no need to hide.
Get through the tide that tries,
Think of the world with wide-open eyes.
See the beauty, stories unfold,
Go where adventures are boldly told.
Want the love that's warm and bold,
Live a tale, forever retold.

HORSES

The horses in my stable
At times stand very still
But sometimes they walk quickly
And slowly mount the hill
Sometimes they make a circle
And gallop round and round

And when they come home
I hear every sound

I HAVE A LITTLE HOUSE

I have a little house,
With new windows and an old door,
Two small chimneys on the top,
And a beautiful plot of grass before.

I have a little house,
With curtains and a blind,
Two small chimneys on the top,
And a plot of grass behind.

I have a little house,
Where I can go in and out,
Two small chimneys on the top,
And a garden all about.

CLASS DIARY

Say a name and the student or students must reply:

I am here

He is not here

She is not here

MY BONNIE LIES OVER THE OCEAN (sit down)

My Bonnie lies over the sea
Well, my Bonnie lies over the ocean
Yeah, bring back my Bonnie to me
Yeah, bring back, ah, bring back

Oh, bring back my Bonnie to me, to me
Ah, bring, oh, bring back, ah, bring back
Oh, bring back my Bonnie to me

THE COW by Robert Louis Stevenson

The friendly cow, all red and white,
I love with all my heart:
She gives me cream with all her might,
To eat with apple tart.
She wanders here and there,
All in the pleasant open air,
In the pleasant light of day.
And blown by all the winds that pass
She walks among the meadow grass

THANK YOU

Thank you
Thank you
Thank you very much
Thank you
Thank you
Thank you very much
Thanks
Thanks a lot
Thanks
Thanks a lot
This is what we say
When we want to say thank you

WHEN I WAS ONE by A.A. Milne (adapted)

When I was one,
I had just begun.
When I was two,
I was nearly new.
When I was three,
I was hardly me.
When I was four,
I want so much more.
When I was five,
I was just alive.
When I was six,
I just ate chips
And now that I am seven,
I am in heaven

JUNE by JOHN UPDIKE

The sun is rich
And gladly pays
In golden hours
Silver days
And long green weeks that never end
School is out
The time is ours to spend

TWO LITTLE EYES TO LOOK AROUND (sit down)

Two little ears to hear each sound,
One little nose to smell what's sweet,
One little mouth that likes to eat

SAYING GOODBYE

Bye, bye
See you tomorrow
See you on Monday

Constructions

First Week

He reads books all the time

I read a book last month

He stops by the bakery on his way home

She stopped at the traffic light

He is paying for a house

They paid for everything.

The company provides excellent service.

The company provided excellent service.

Second Week

She often loses her keys

She lost her keys last year.

I understand the rules.

I understood the rules.

They wait for the bus every morning.

They waited for the bus yesterday morning.

They meet for lunch every day.

They met their friends yesterday.

She thanks everyone for their support.

She thanked him for his assistance yesterday.

She changes her hairstyle often.

She changed her hairstyle last week.

Third Week

She watches soccer every evening.

She watched a movie last night.

She sits at her desk every morning.

She sat on the bench at the park yesterday

She creates beautiful artwork in her spare time.

She created a stunning painting last weekend.

She learns English every day.

Last year she learned English every day

She includes everyone in her class.

She included sugar to her diet last week.

Books

Mondays

The Amazing Planet Earth

One Hundred Shoes

Tuesdays

Ten in the bed

Wake Up, Sun!

Wednesdays

The Wonky Donkey

Silly Sara

Thursdays

The Amazing Planet Earth

One Hundred Shoes

Fridays

Ten in the bed

Wake Up, Sun!

Mondays

The Wonky Donkey

Silly Sara

Books to be copied and read by the
kids in class

Spot Looks at Opposites
The Pup Speaks Up
I Like Bugs (Two days)
Spot Says Please (Three Days)

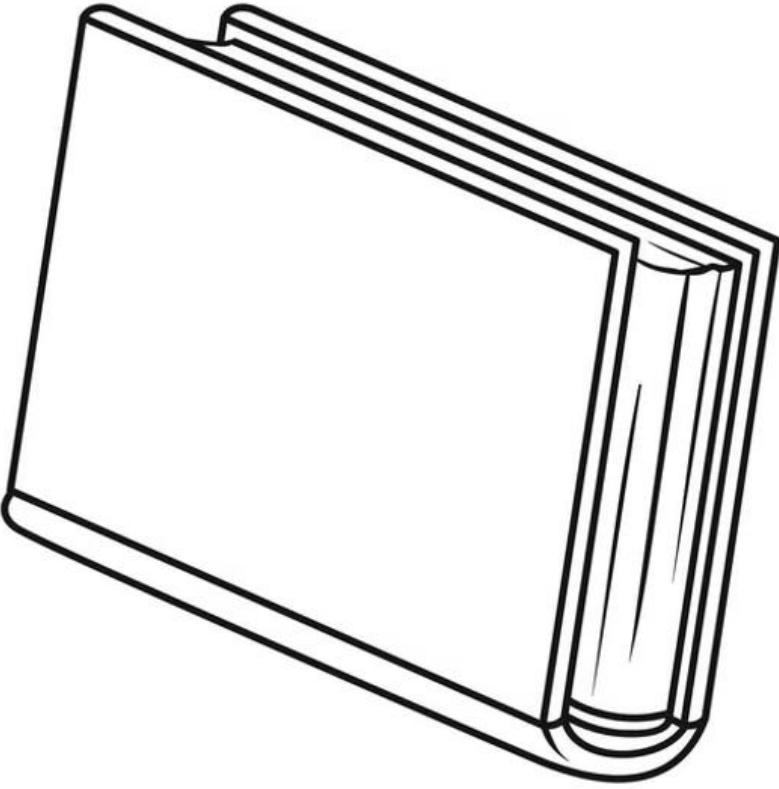

book

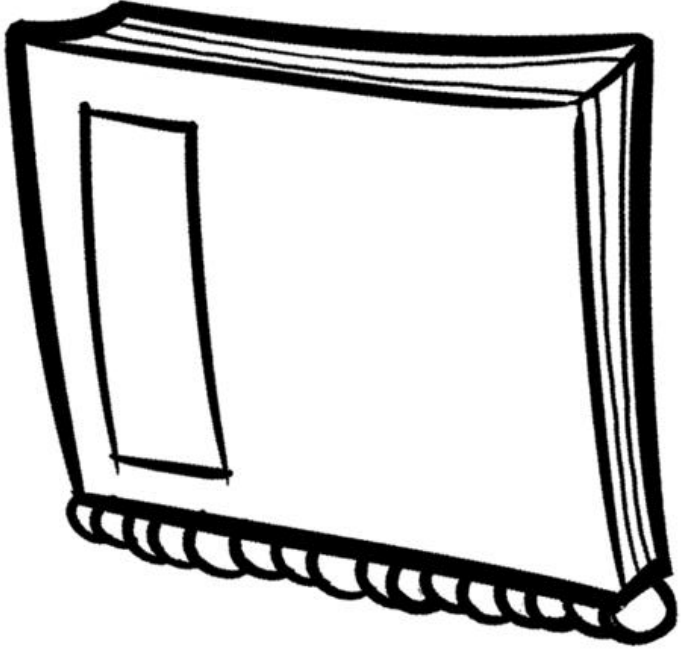

notebook

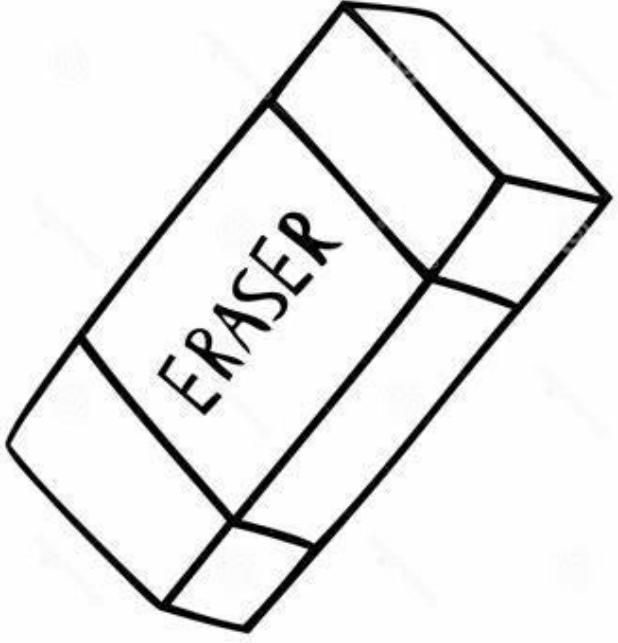

eraser

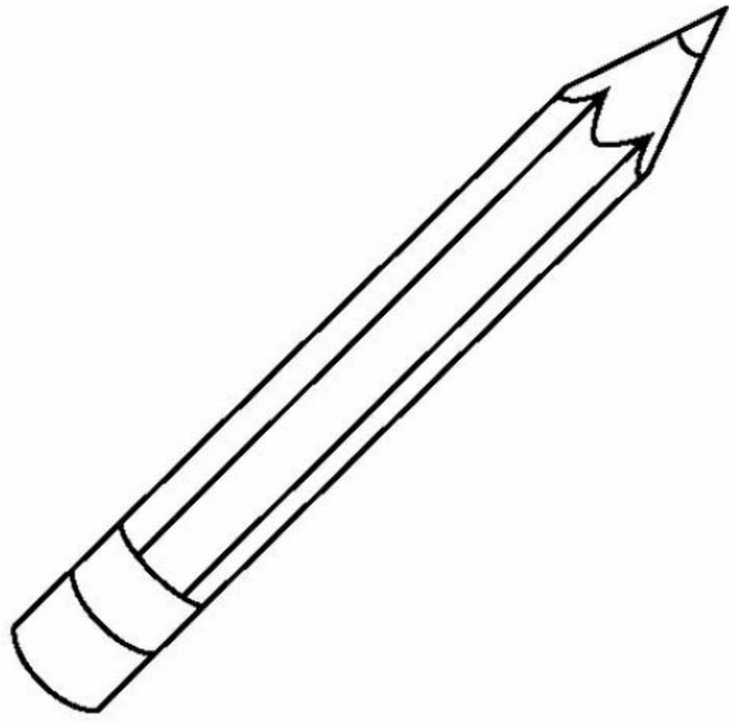

pencil

I am here.

He is not here.

She is not here.

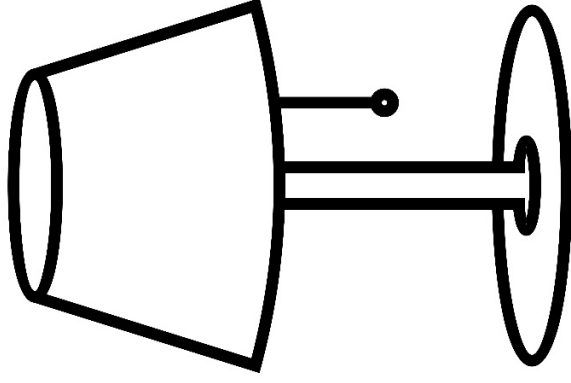
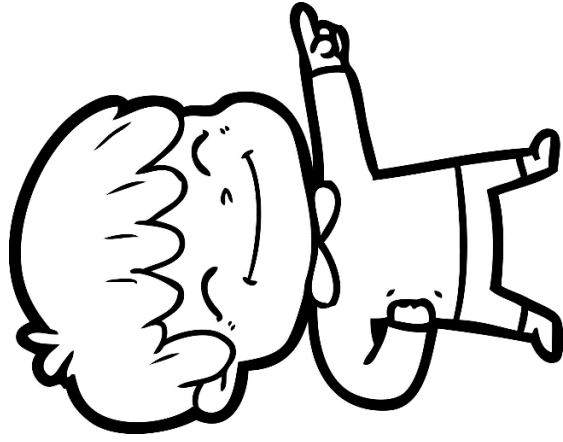

This is a lamp.

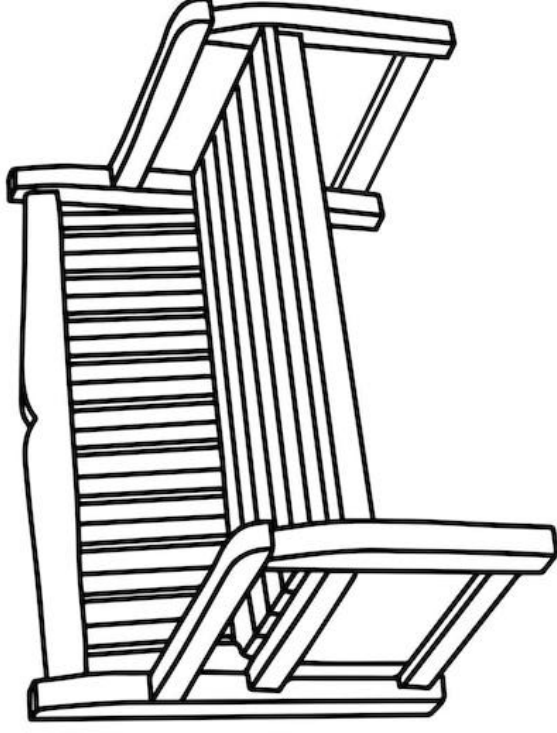
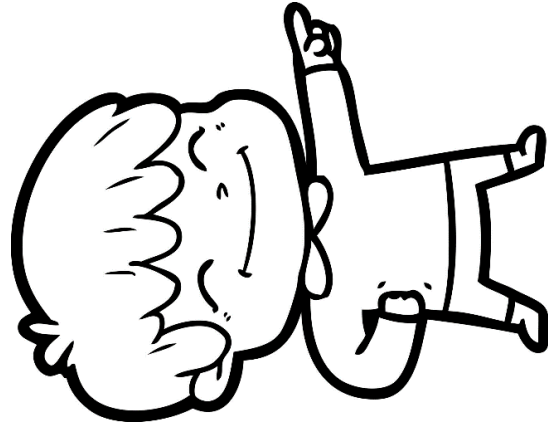

This is a bench.

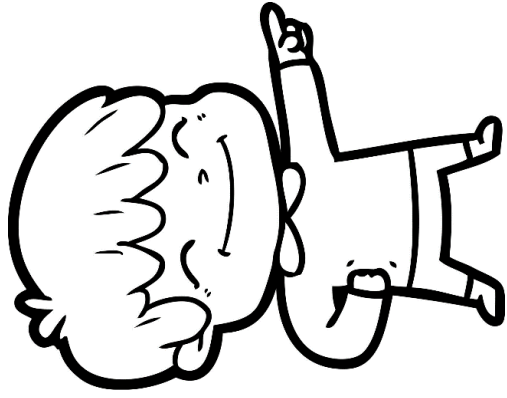

That is a window.

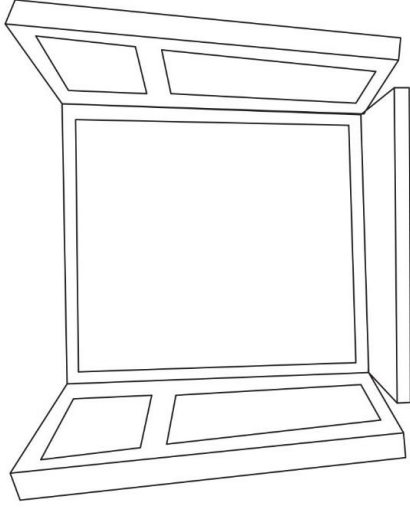

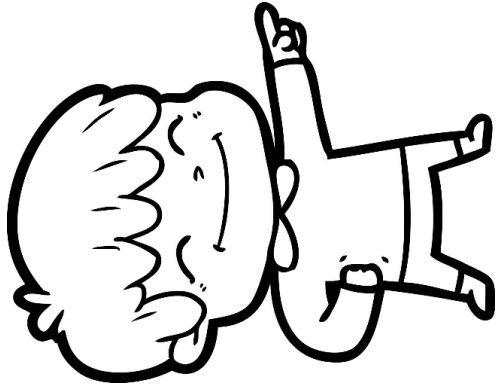

That is a blackboard.

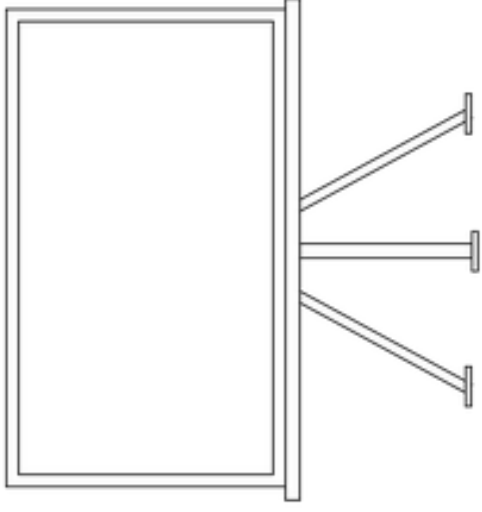

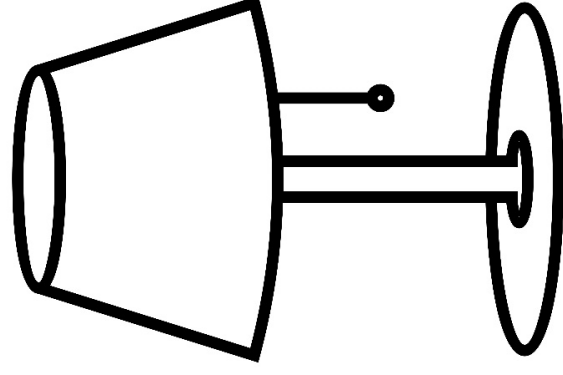
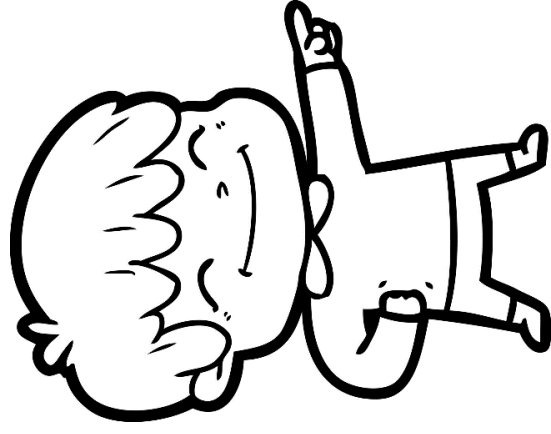

This is not a bench.

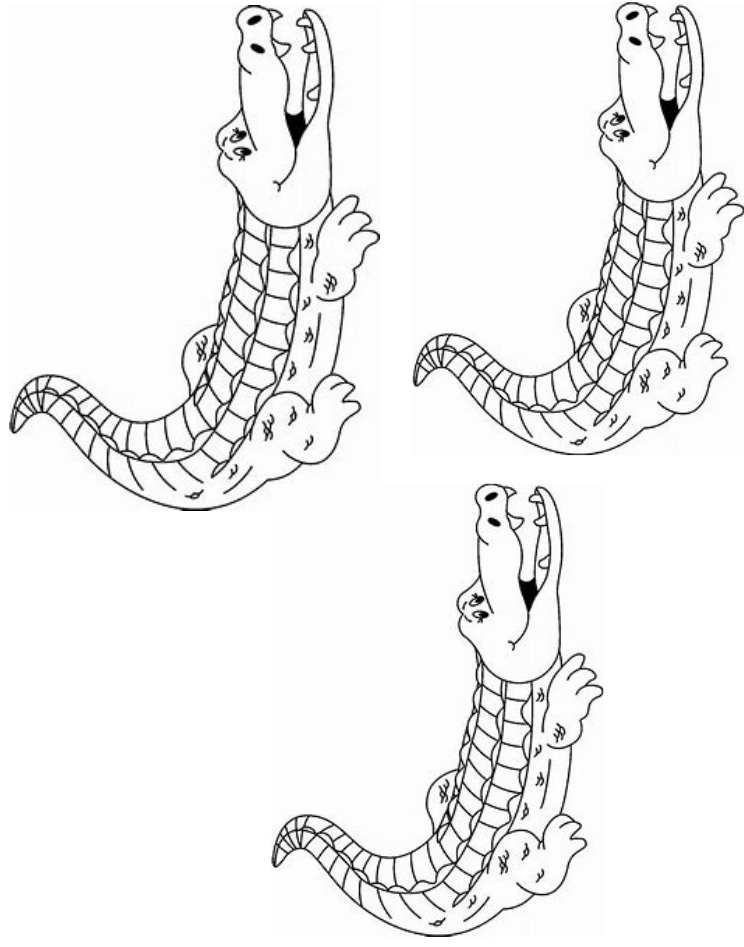
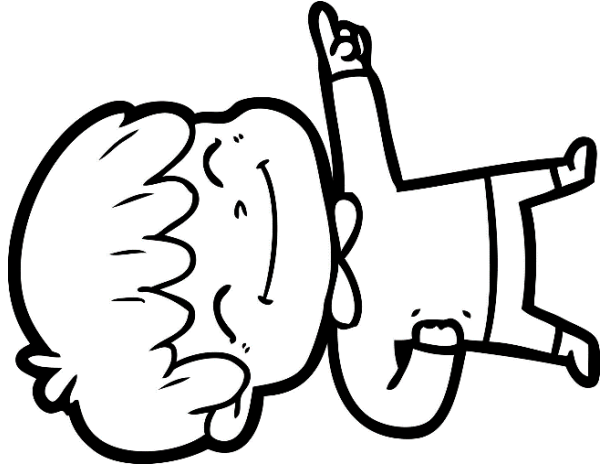

These are not lamps.

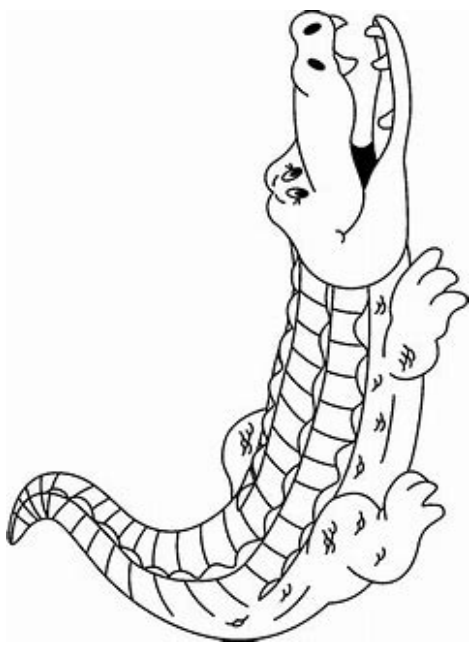
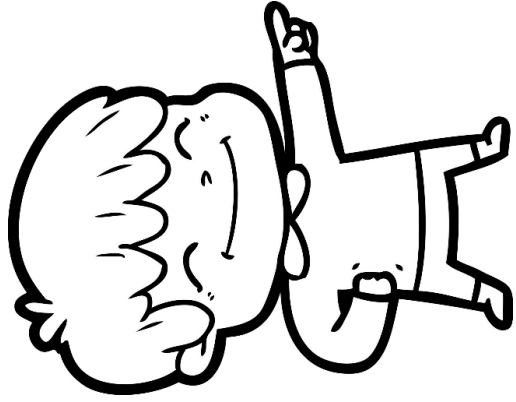

That is not a window.

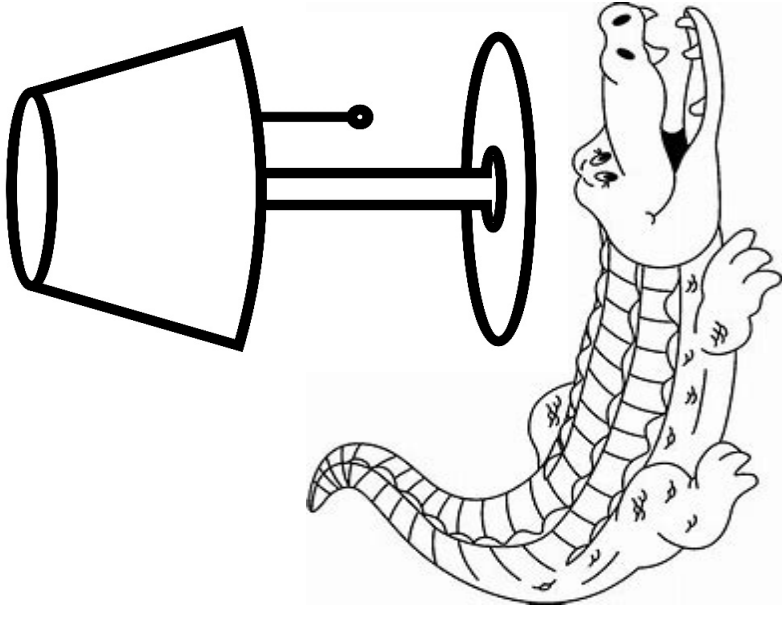
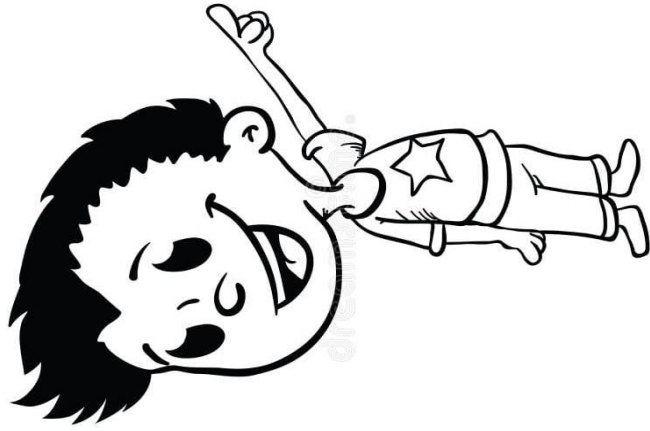

Those aren't blackboards.

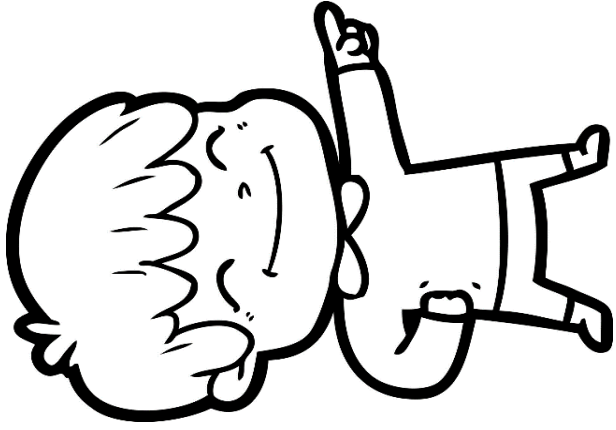

This is a foot.

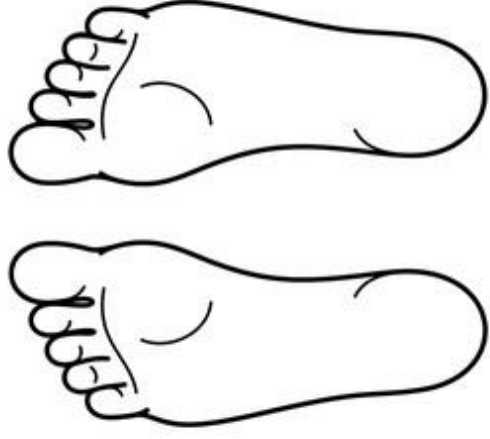
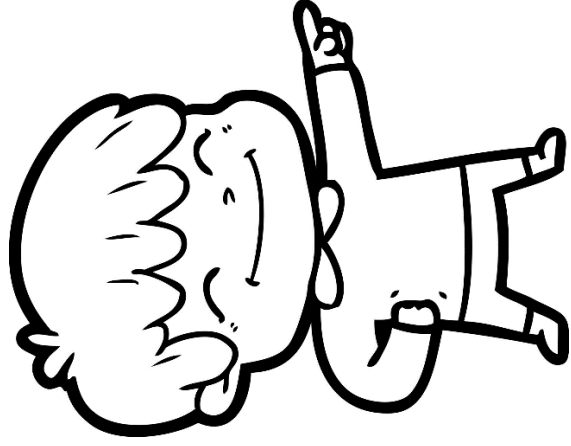

These are feet.

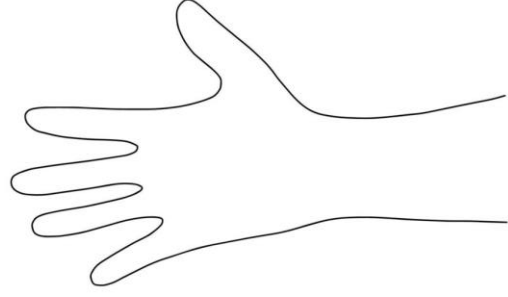
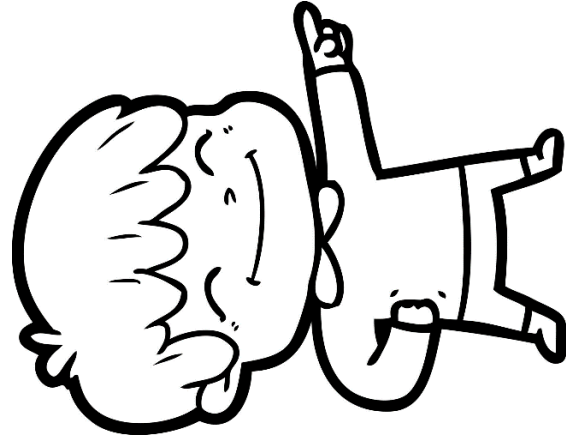

This is a hand.

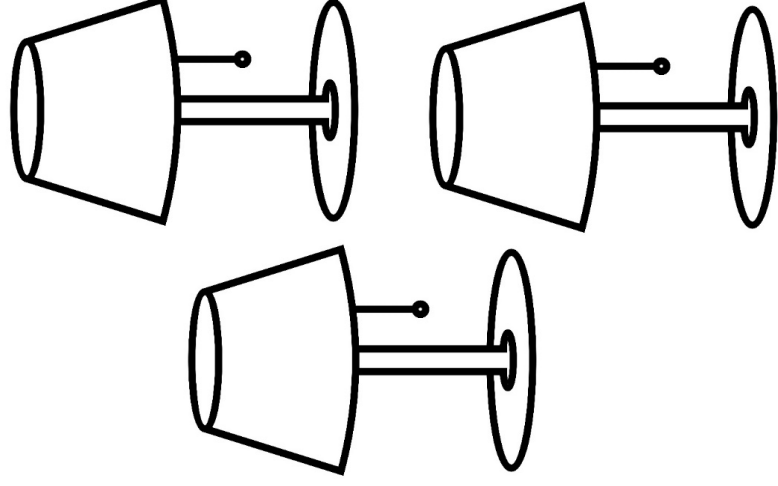

These aren't two hands.

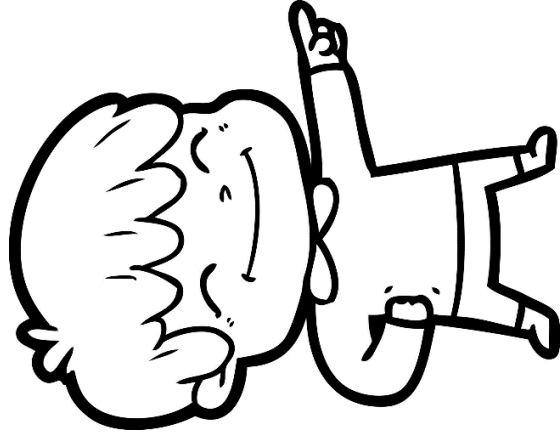

This is a dog.

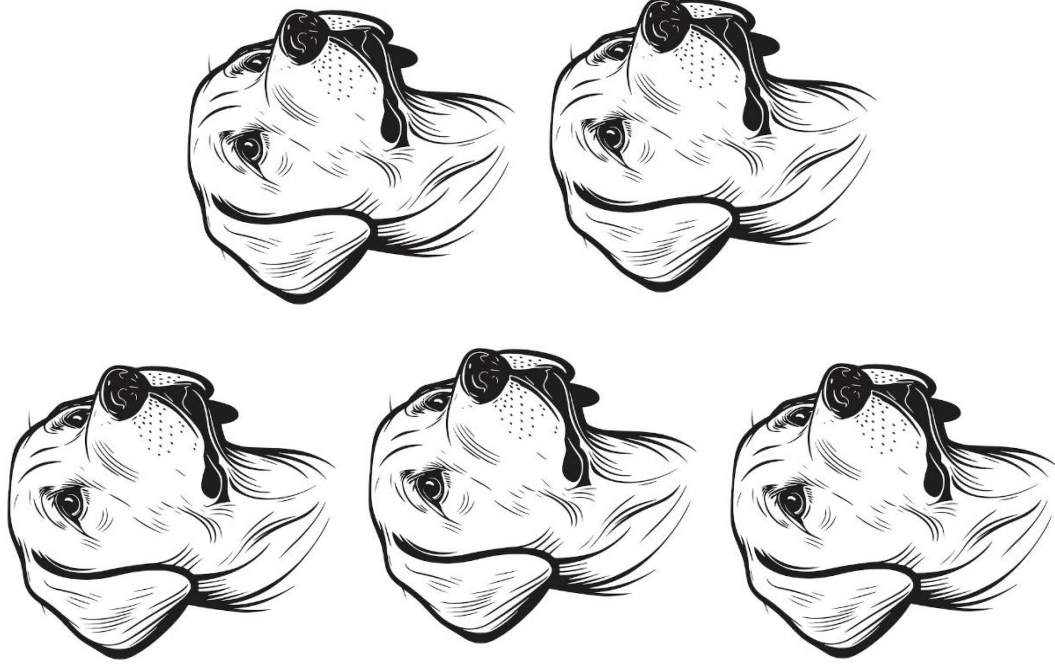
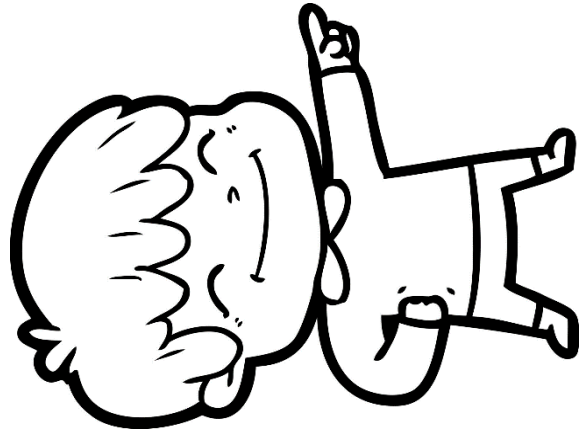

These are five dogs.

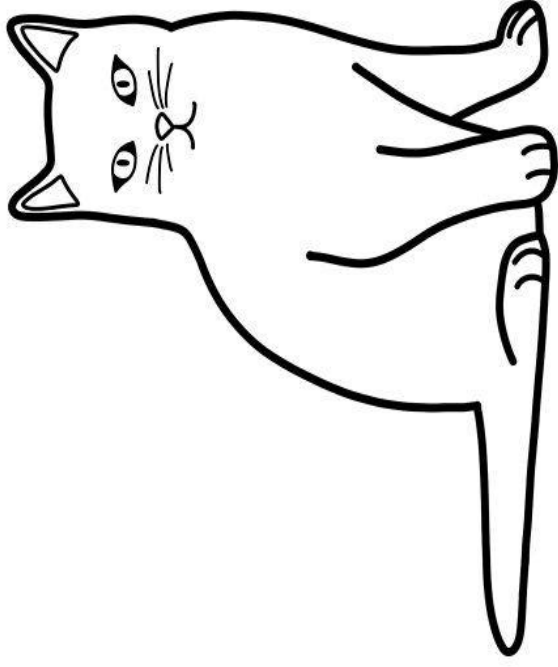
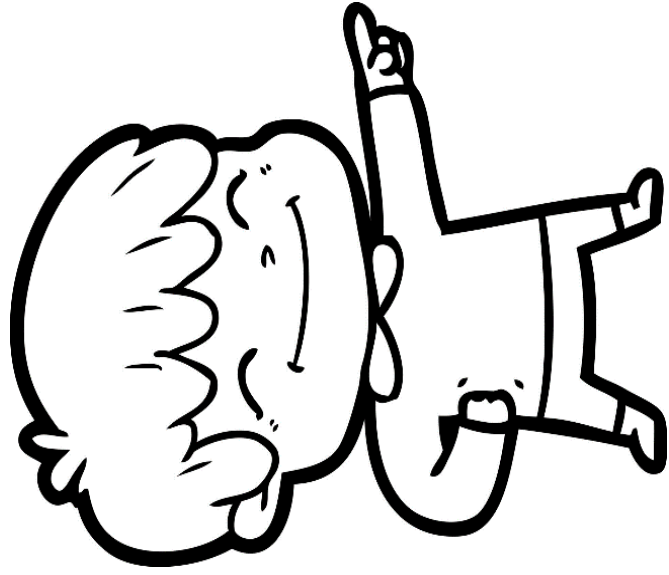

This is a cat.

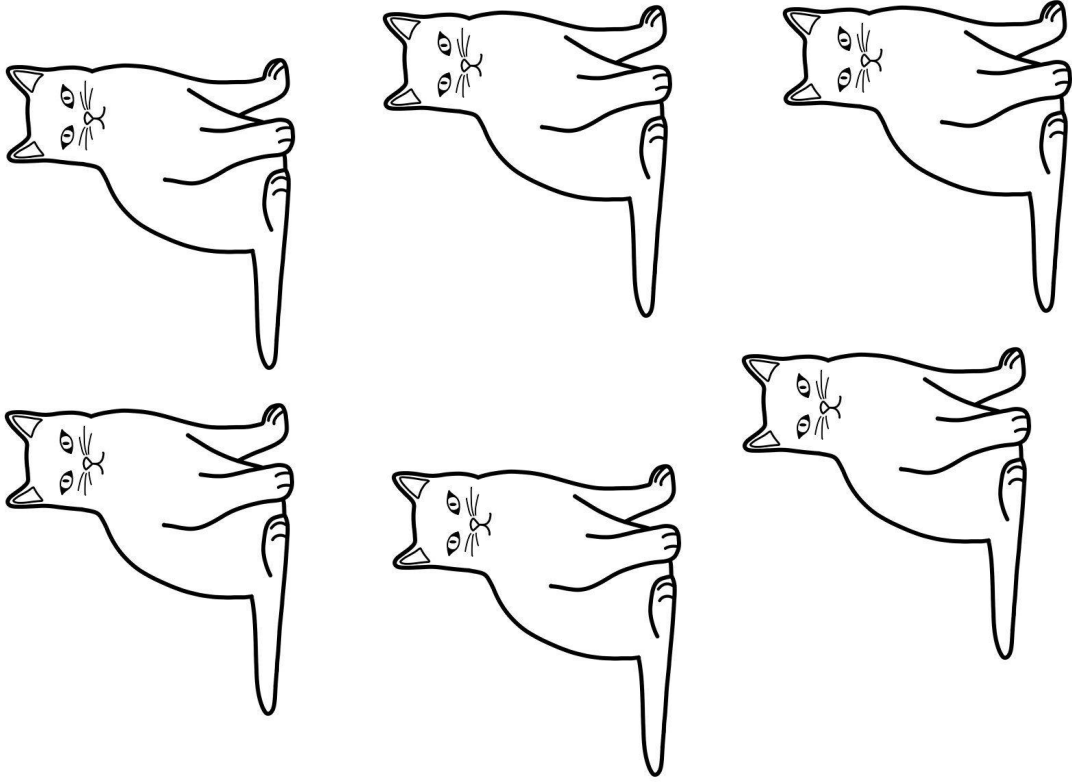
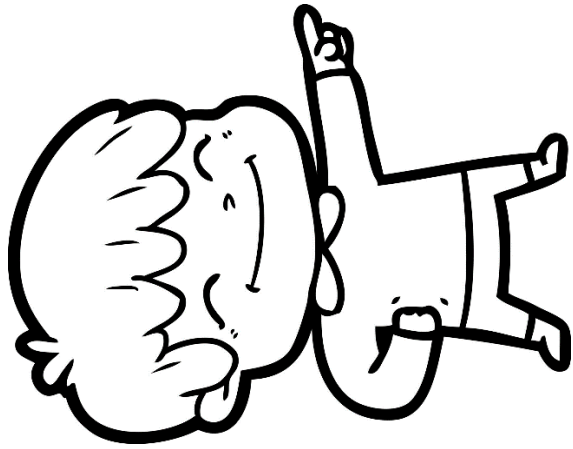

These are six cats.

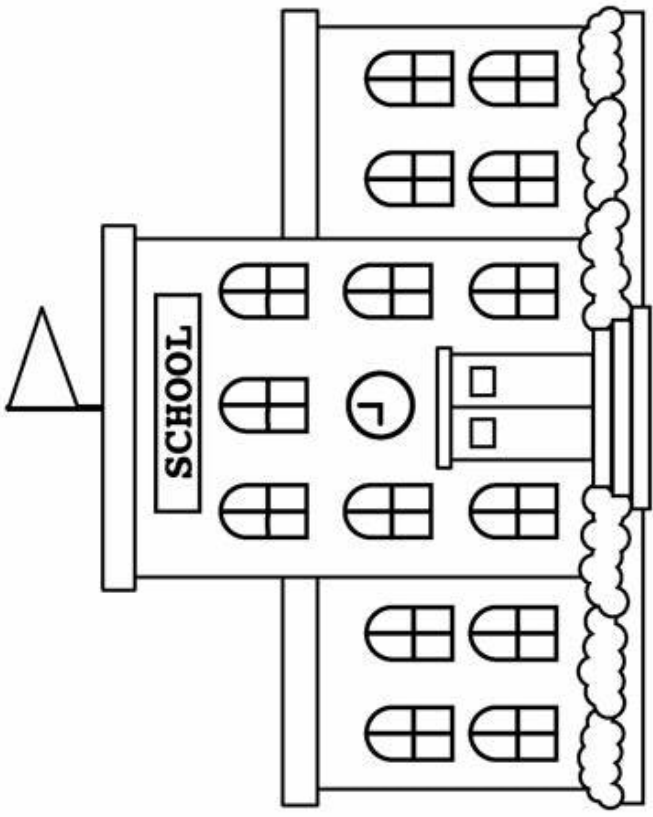
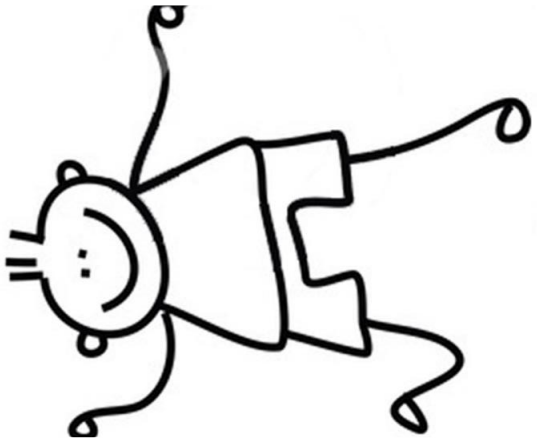

I **am** in school.

I **am not** in school.

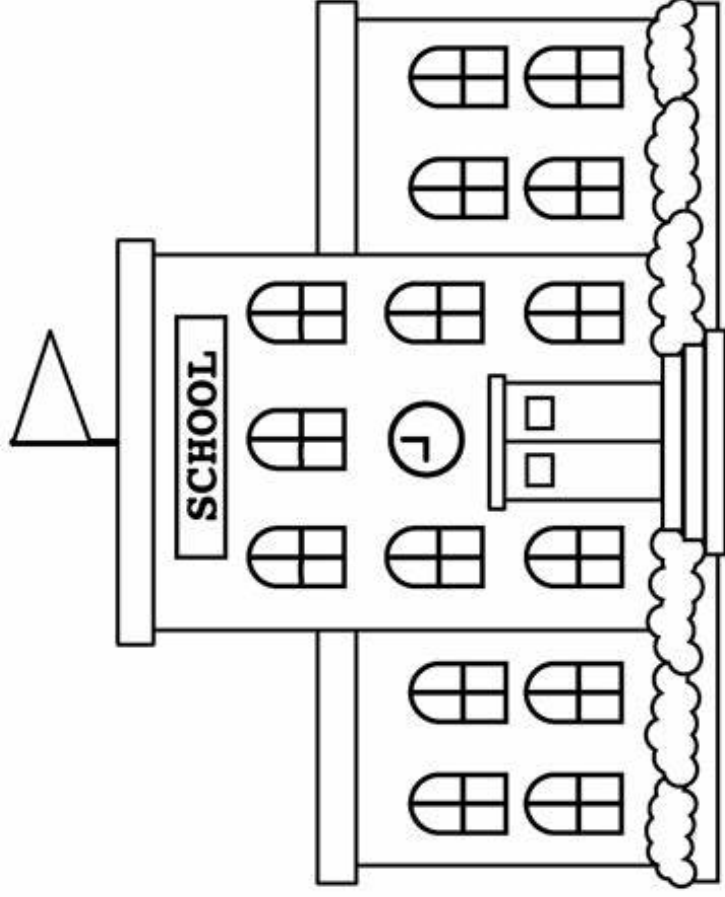
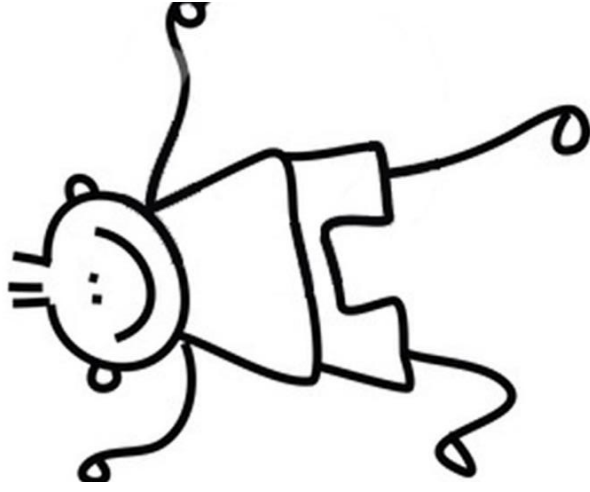

I **was** in school.

I **was not** in school.

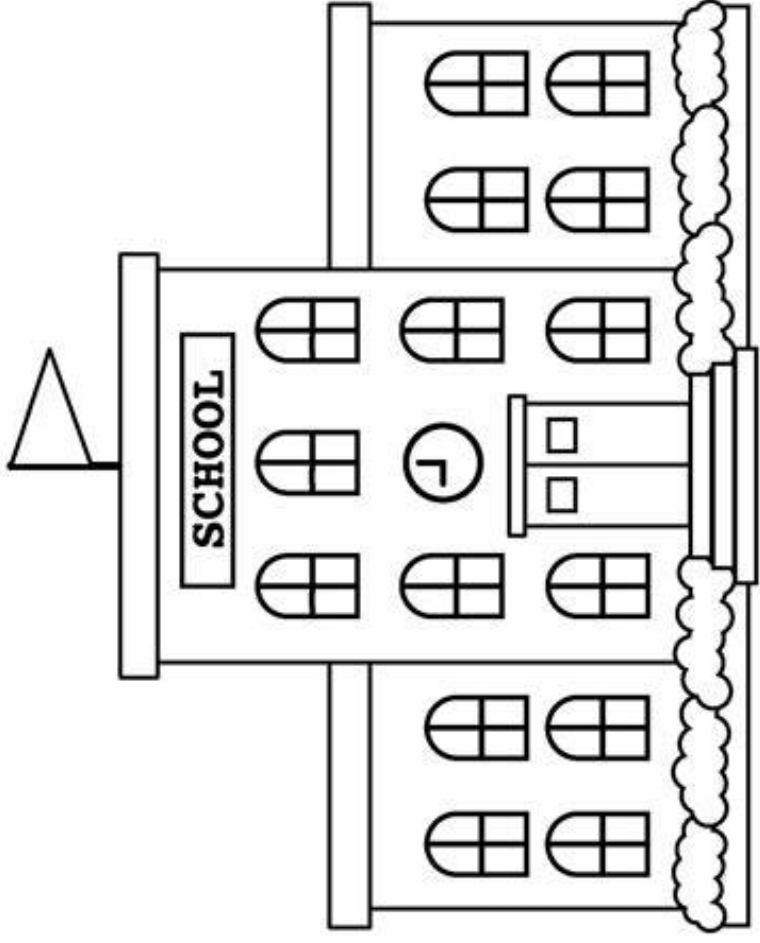
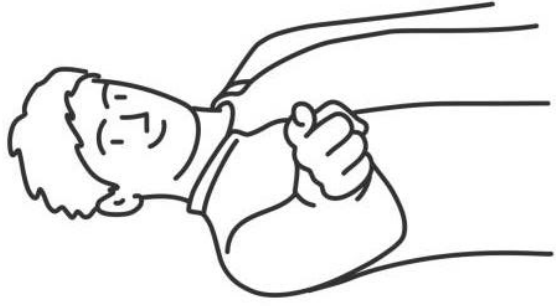

You **are** in school.

You **are not** in school.

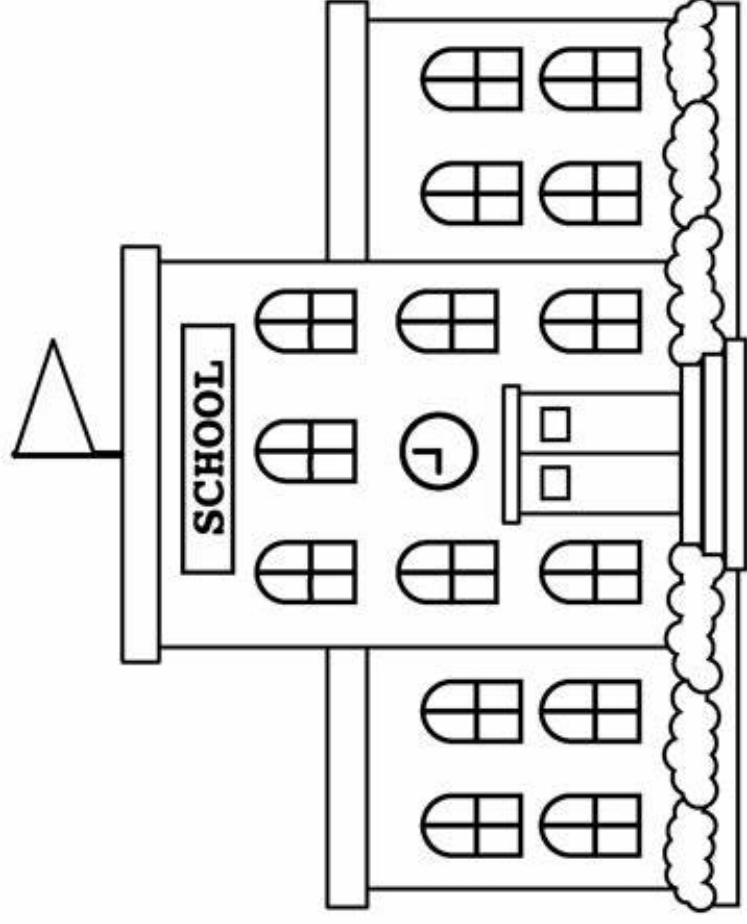
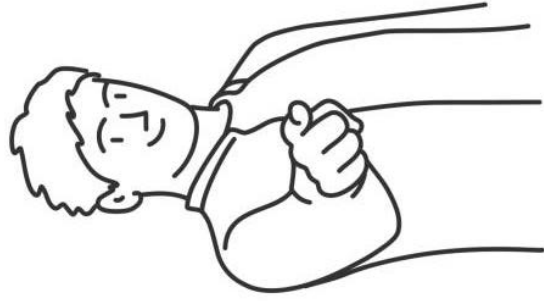

You **were** in school.

You **were not** in school.

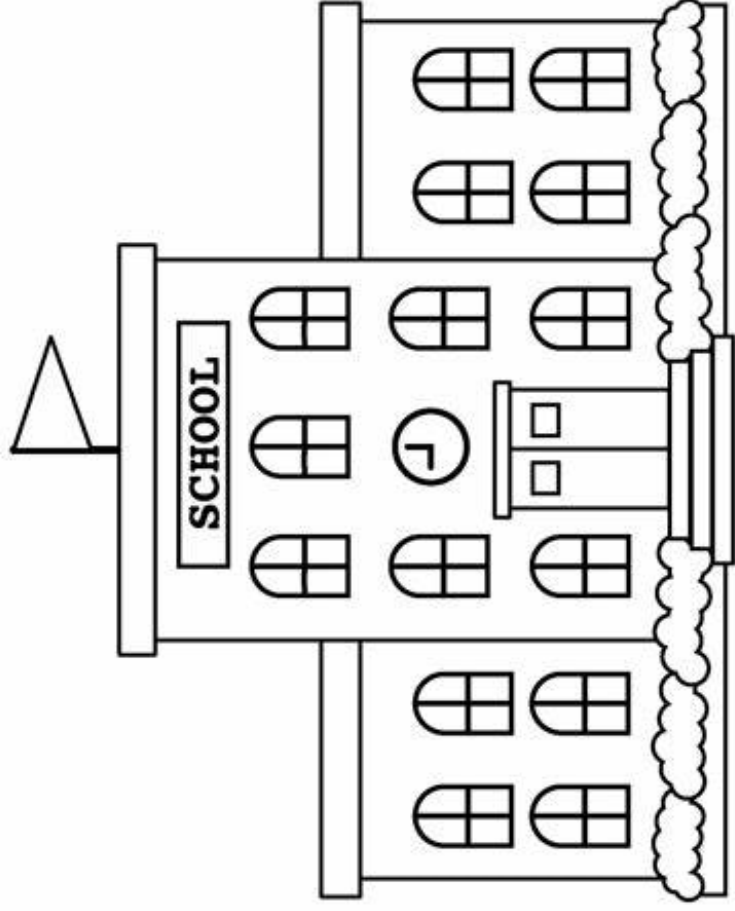
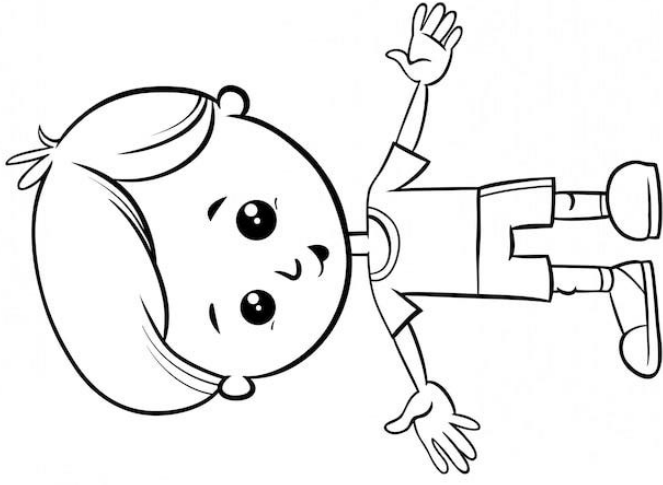

He **is** in school.

He **is not** in school.

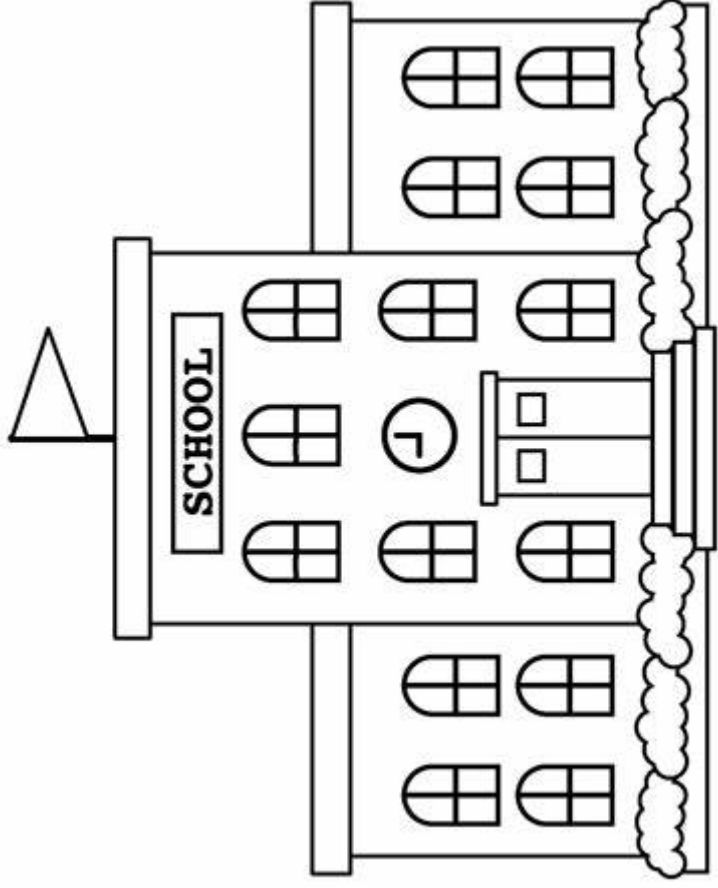
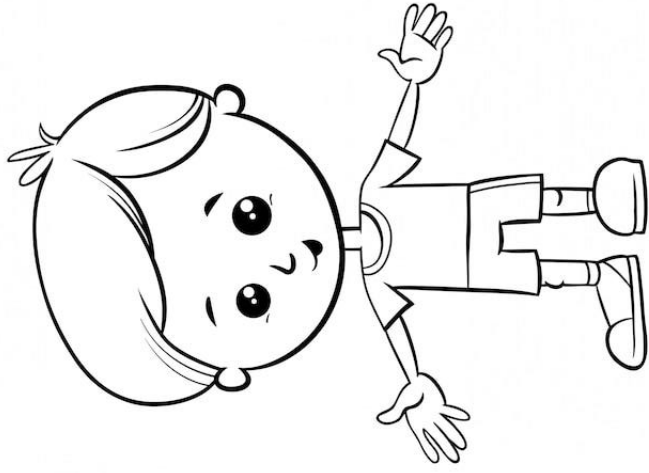

He **was** in school.

He **was not** in school.

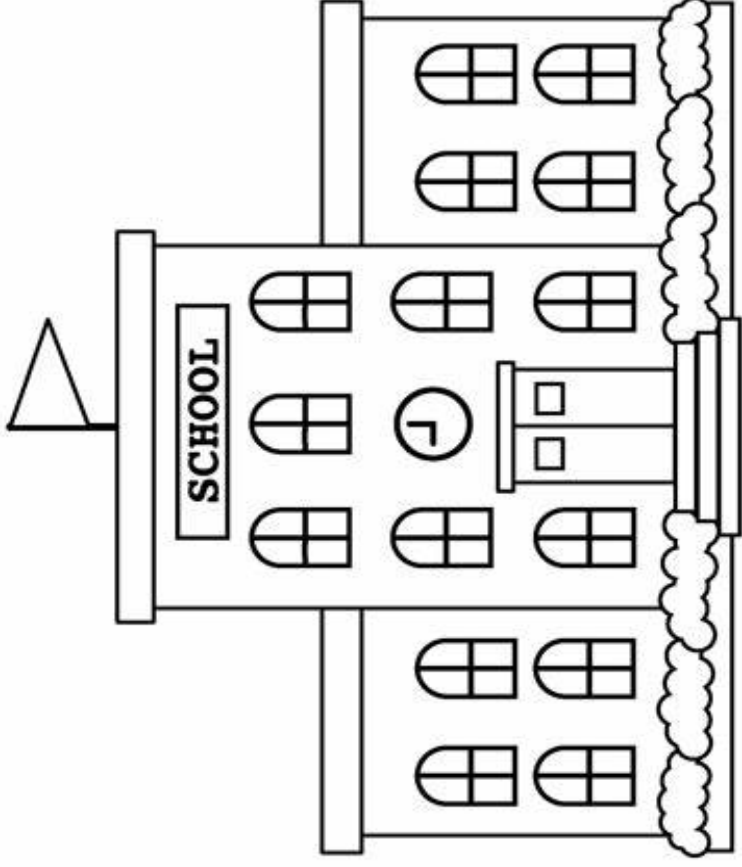
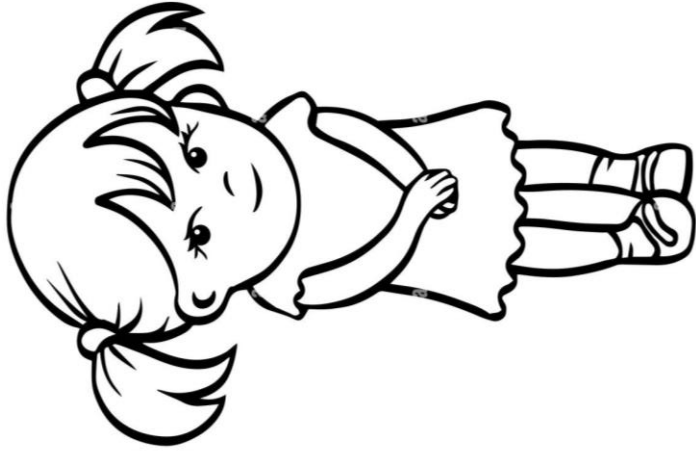

She **is** in school.

She **is not** in school.

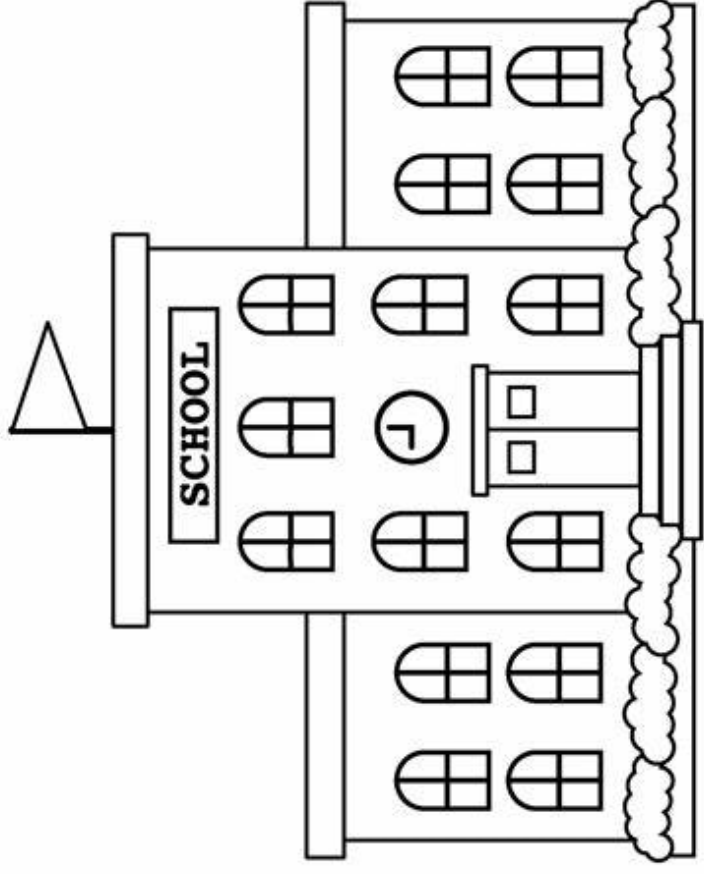
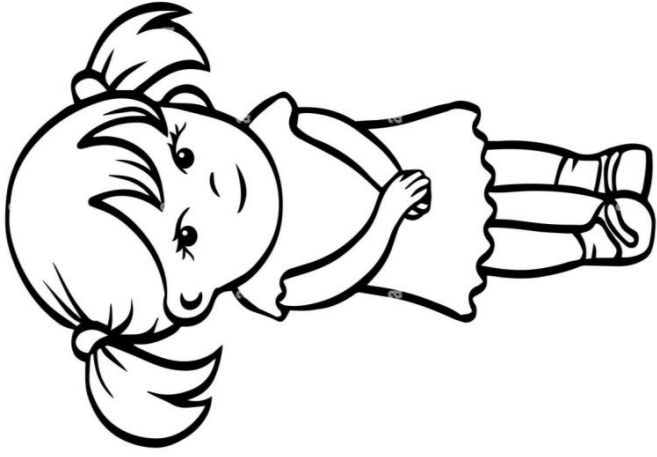

She **was** in school.

She **was not** in school.

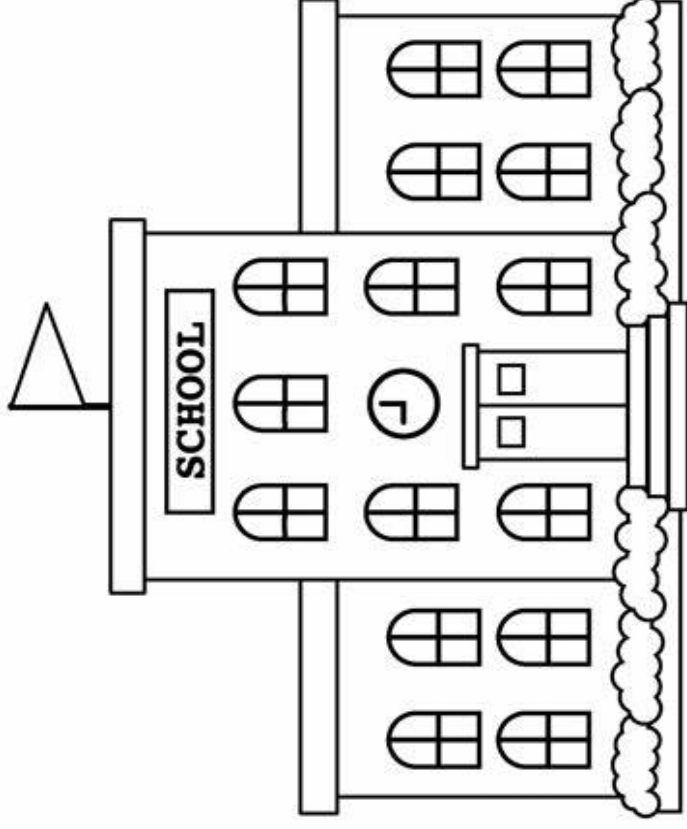
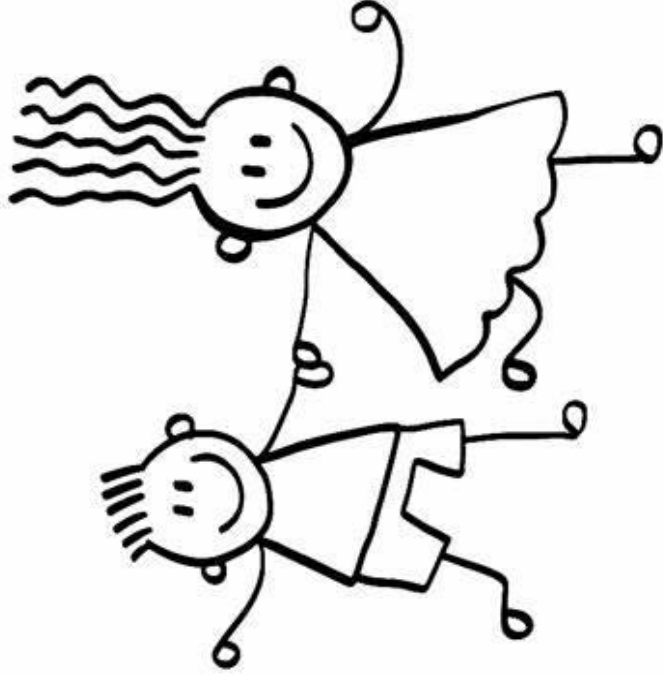

We **are** in school.

We **are not** in school.

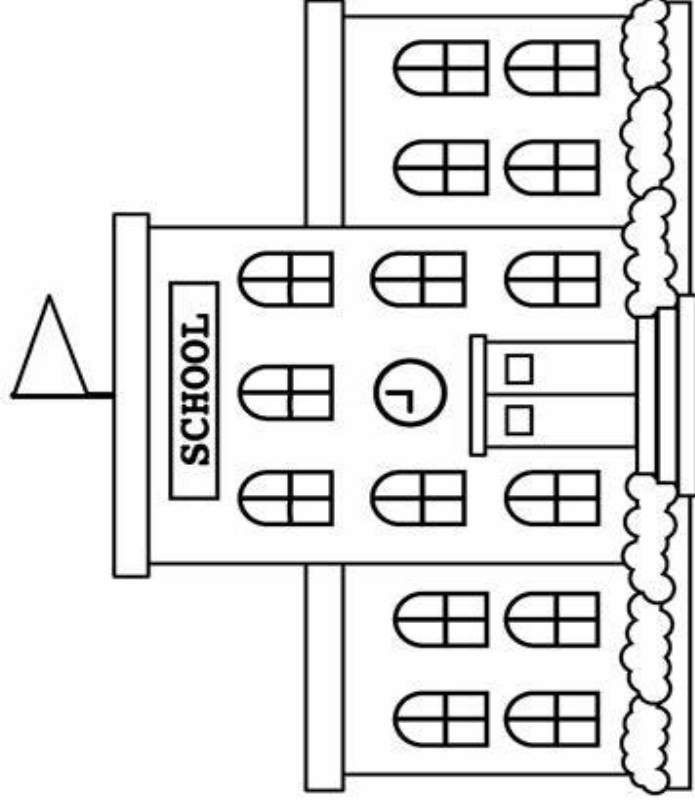
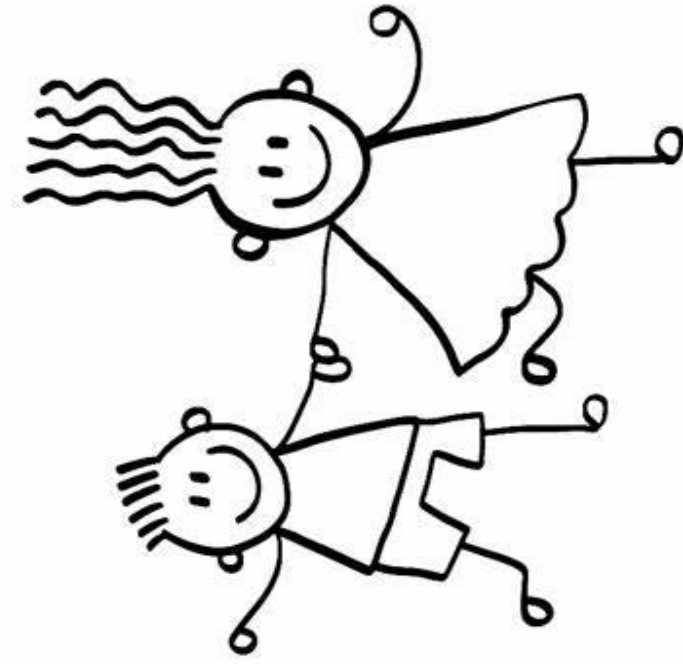

We **were** in school.

We **were not** in school.

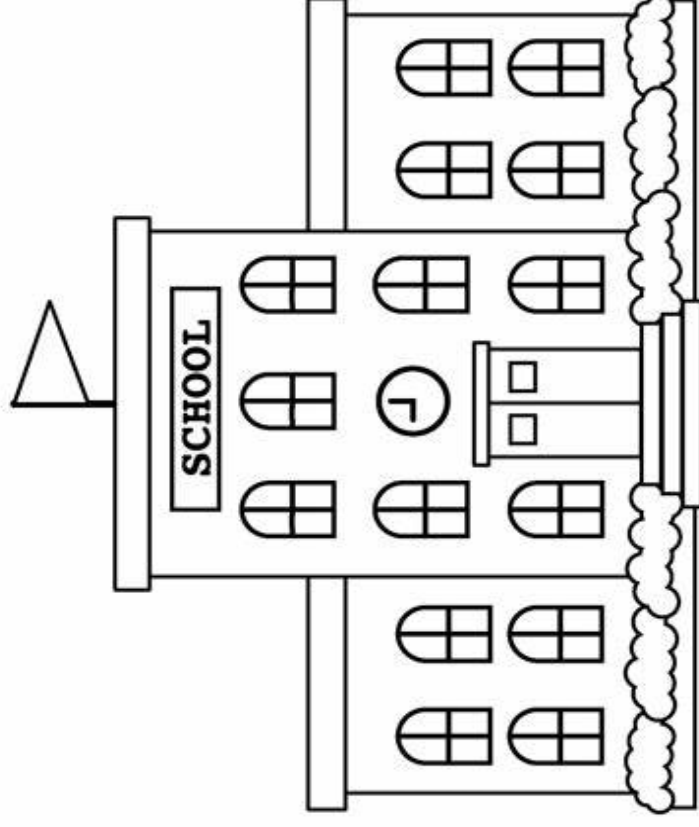
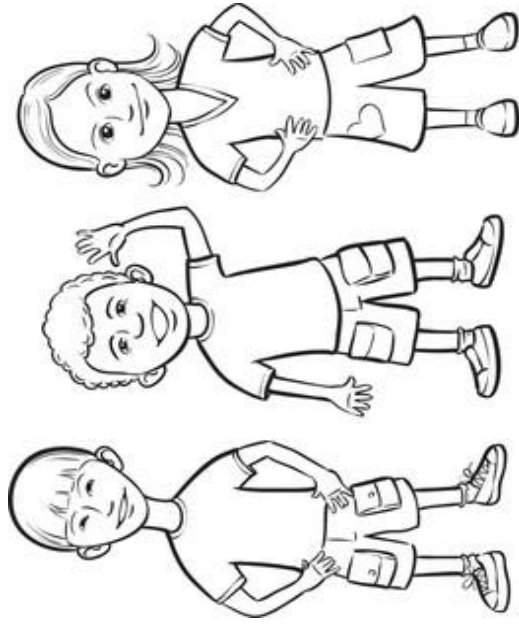

They **are** in school.

They **are not** in school.

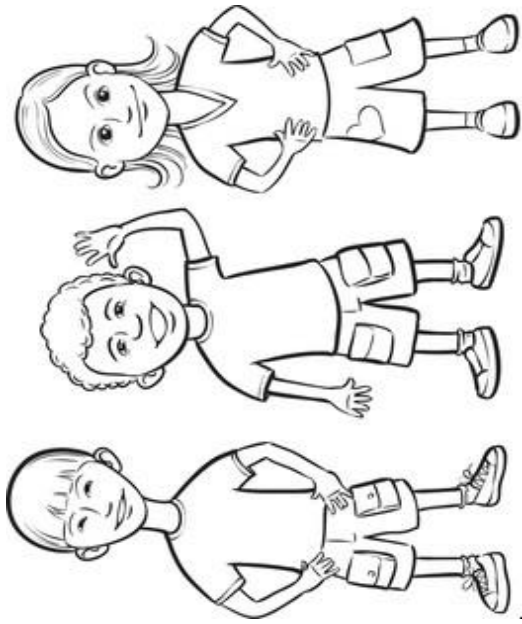
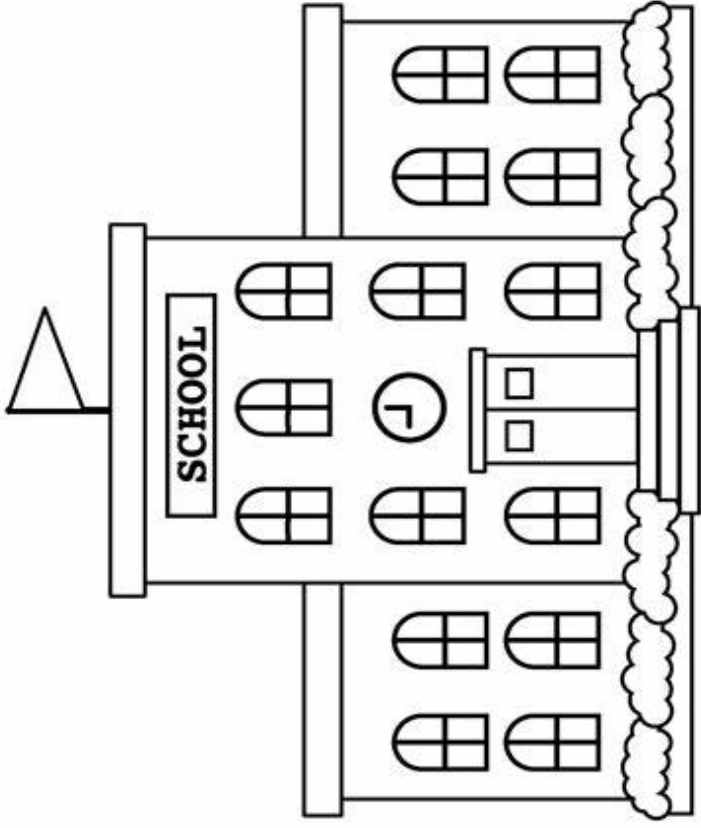

They **were** in school.

They **weren't** in school.

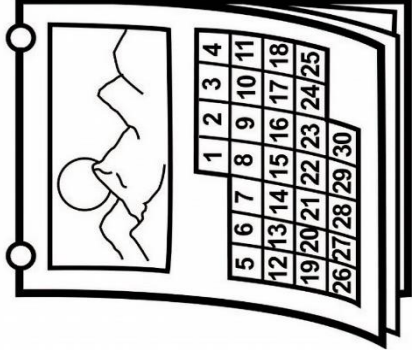
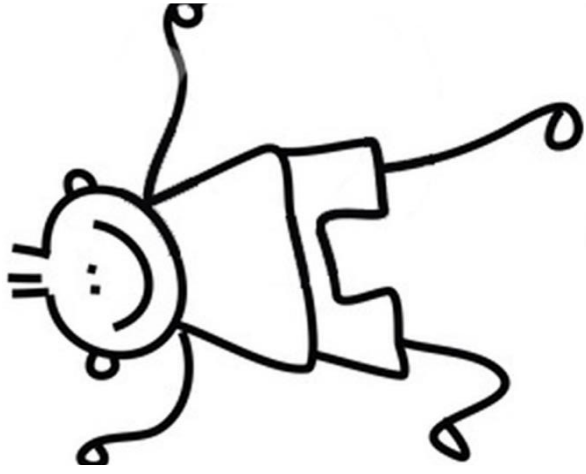

I **do** my homework every day.

I **don't do** my homework every day.

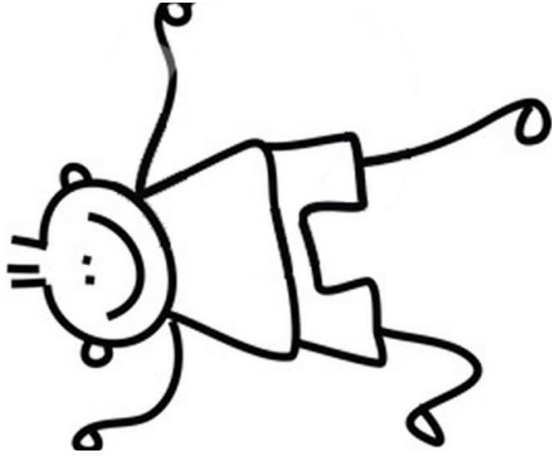

I **did** my homework last week.

I **didn't do** my homework last week.

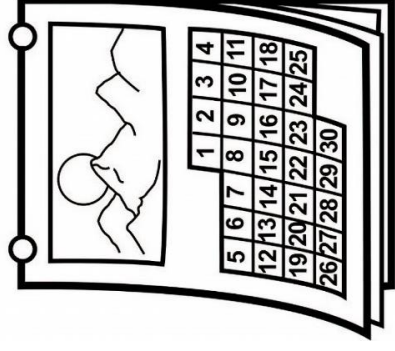

You **do** your homework every day.

You **don't do** your homework every day.



You **did** your homework last week.

You **didn't do** your homework last week.

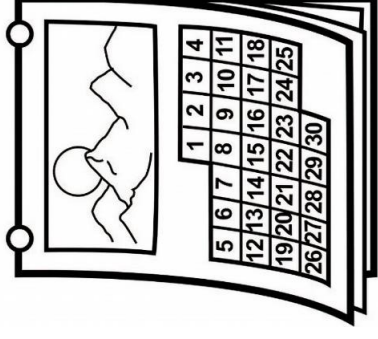
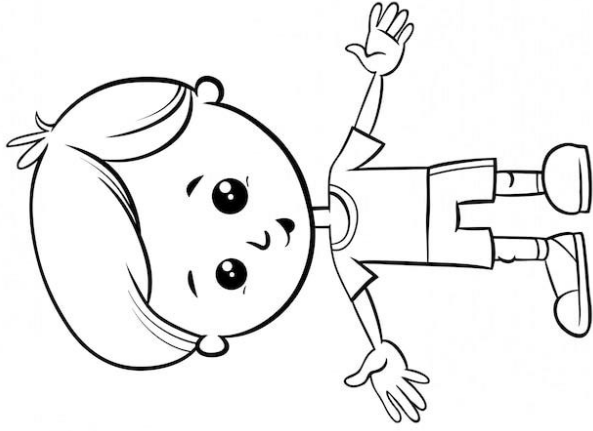

He **does** his homework every day.

He **doesn't do** his homework every day.

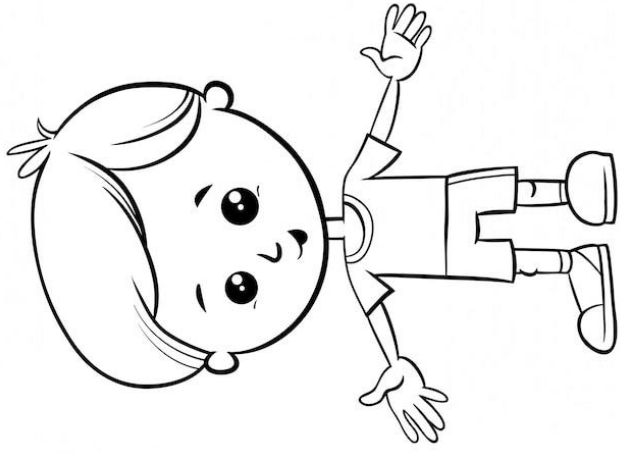

He **did** his homework last week.
He **didn't do** his homework last week.

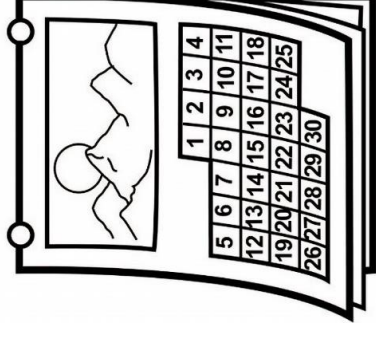
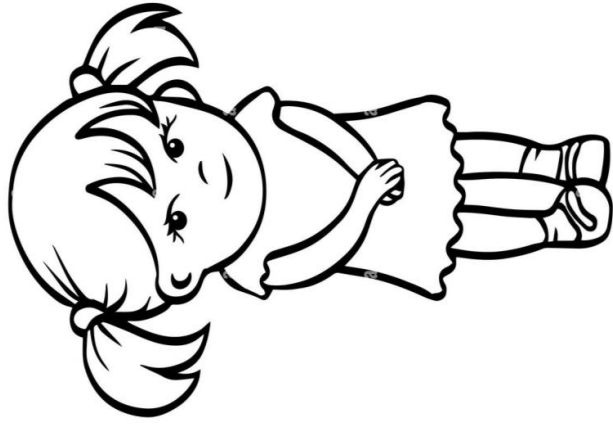

She **does** her homework every day.

She **doesn't do** her homework every day

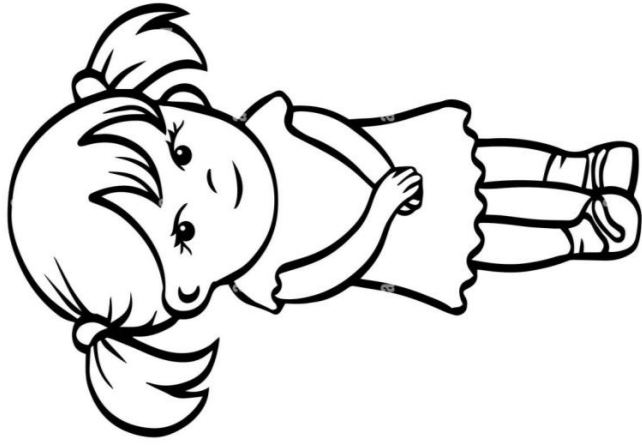

She **did** her homework last week.

She **didn't do** her homework last week.

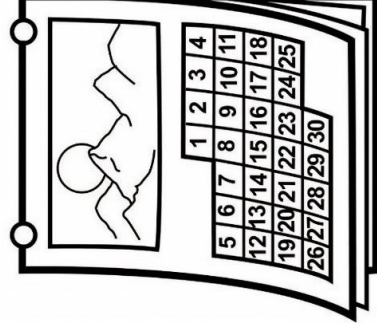
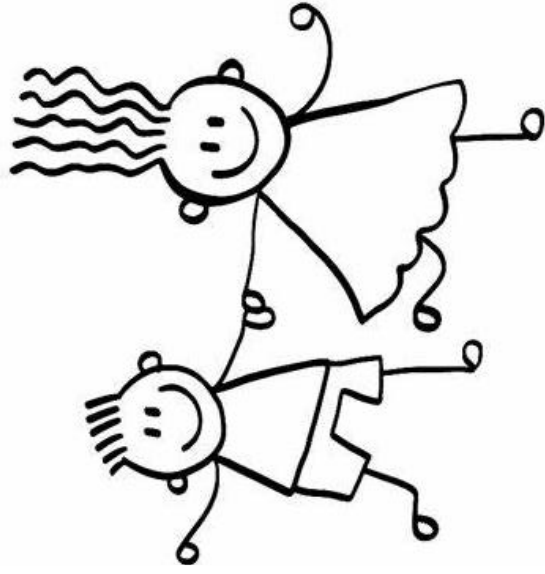

We **do** our homework every day.
We **don't do** our homework every day.

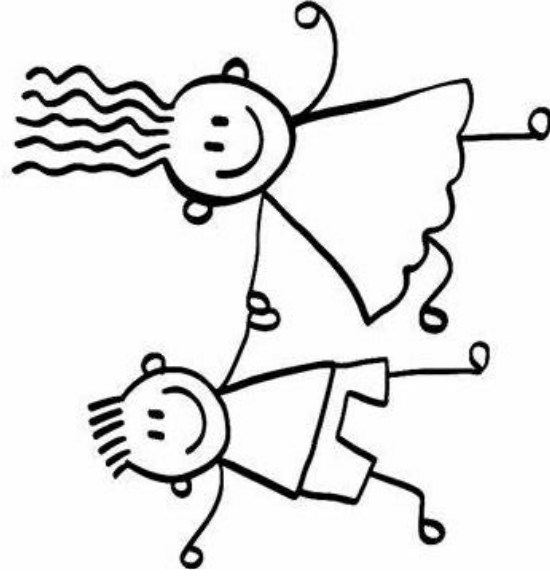

We **did** our homework last week.

We **didn't do** our homework last week.

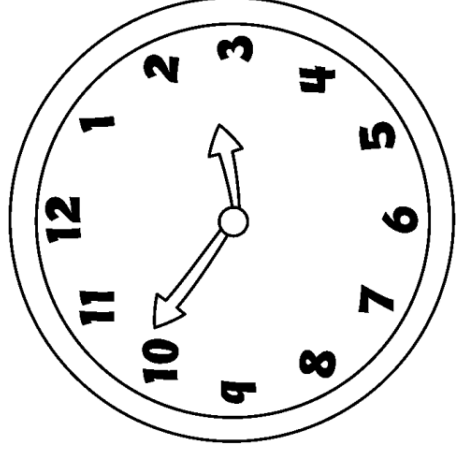
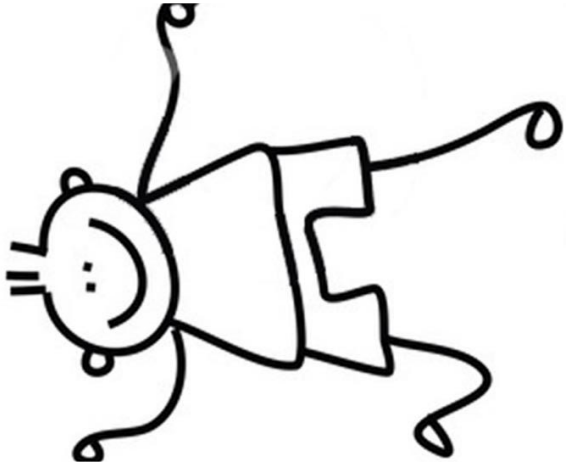

I **have** time.

I **don't have** time.

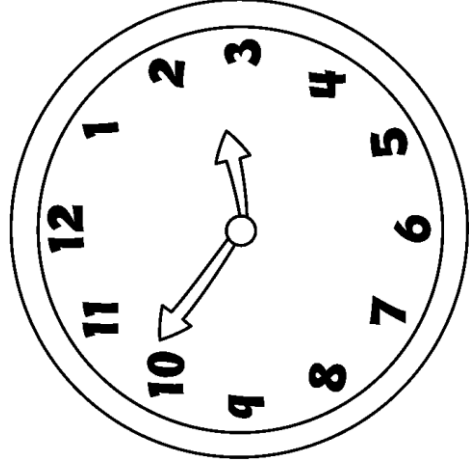
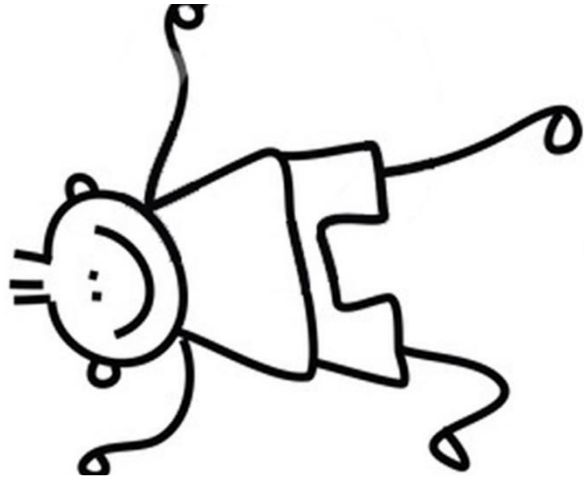

I **had** time.

I **didn't have** time.

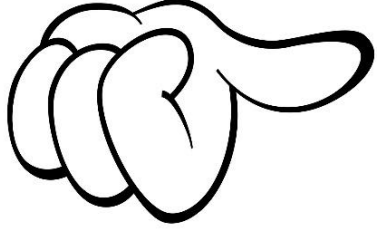
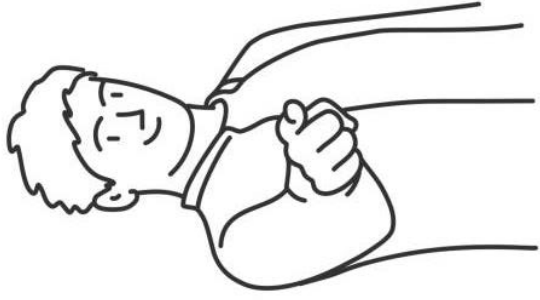

You **have** a bad job.

You **don't have** a bad job.

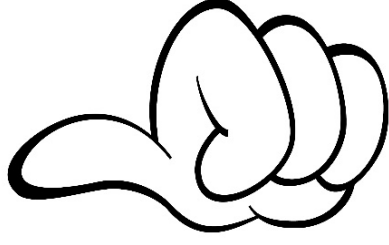
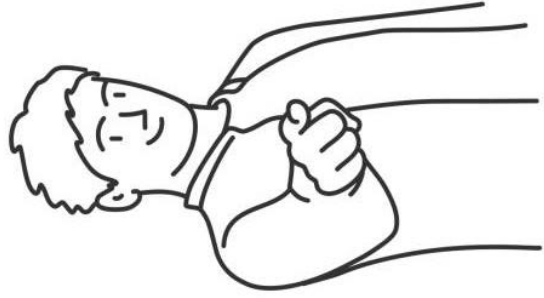

You **had** a good life.

You **didn't have** a good life.

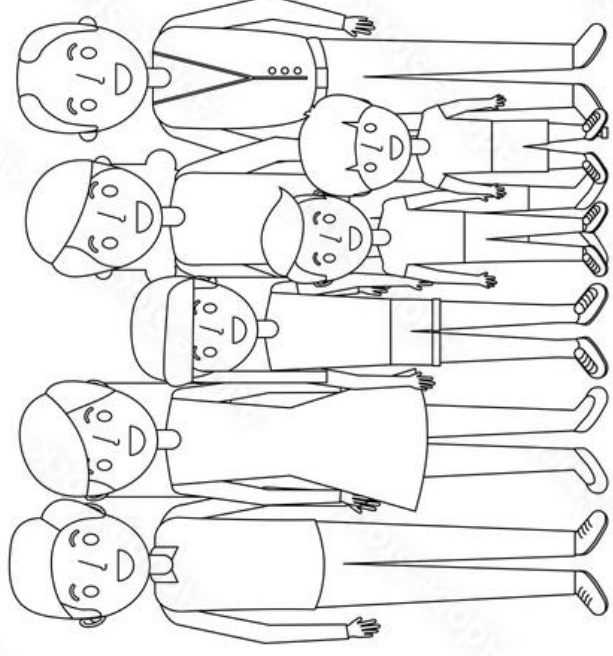
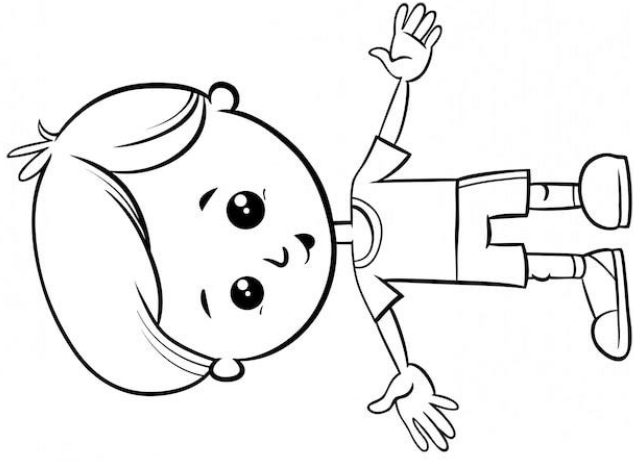

He **has** a big family.

He **doesn't have** a big family.

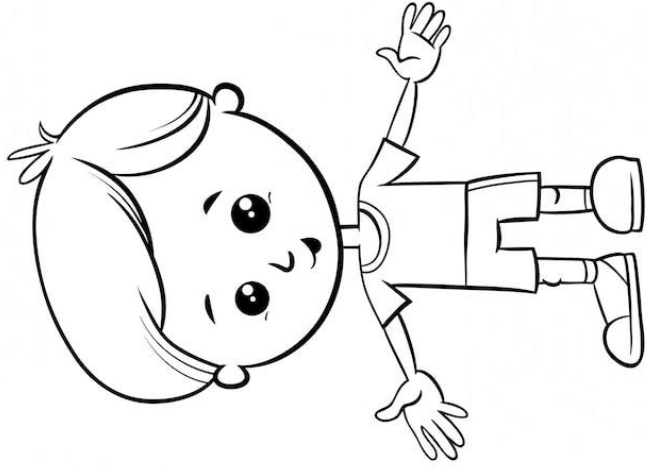

He **had** a small family.

He **didn't have** a small family.

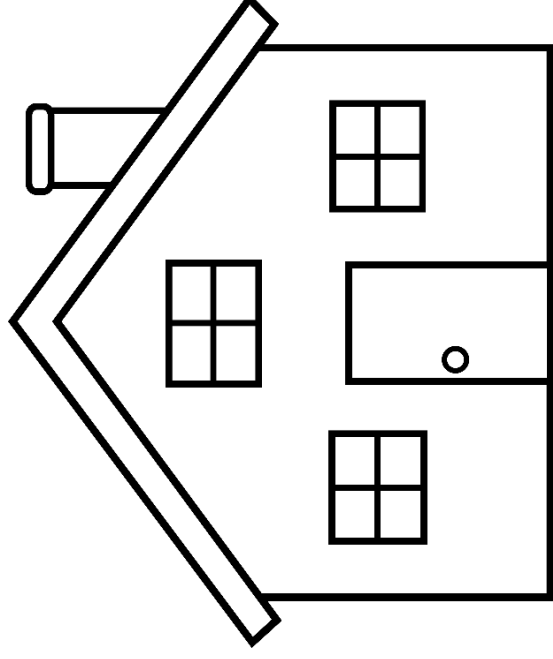
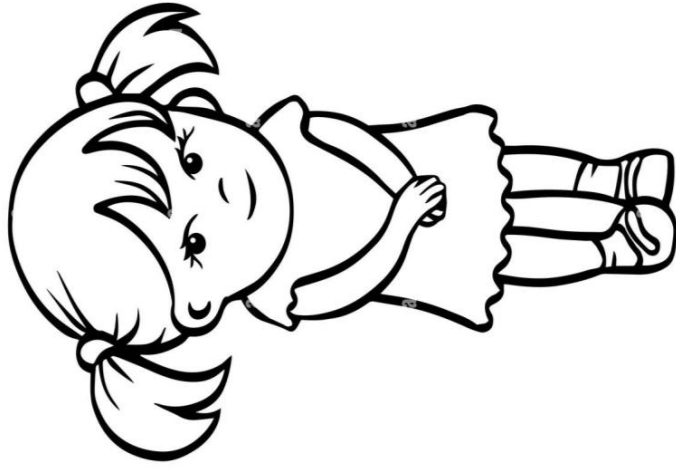

She **has** a little house.

She **doesn't have** a little house.

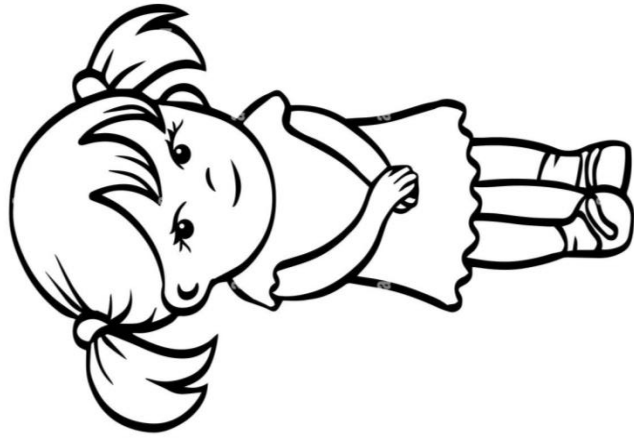

She **had** a long night.

She **didn't have** a long night.

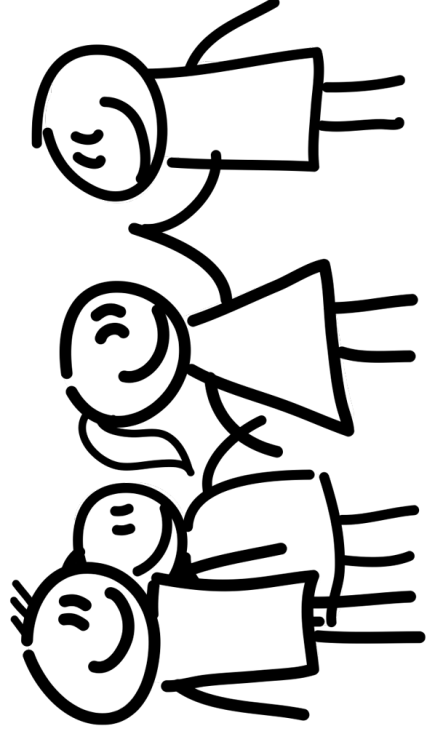
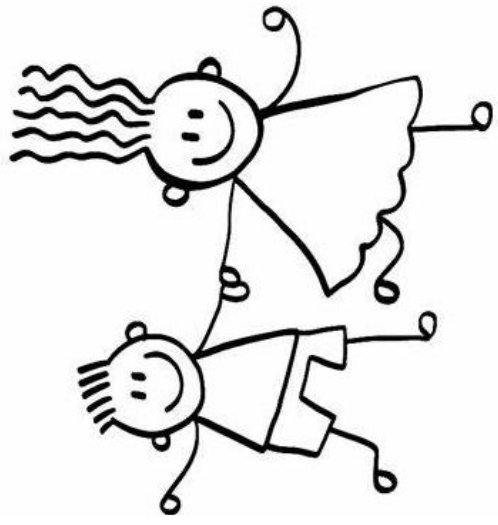

We **have** different friends.

We **don't have** different friends.

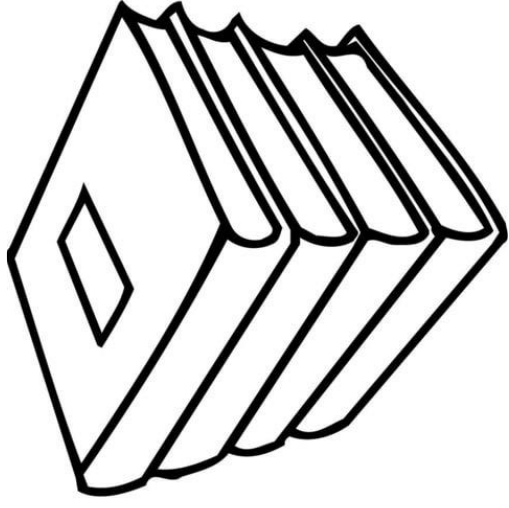
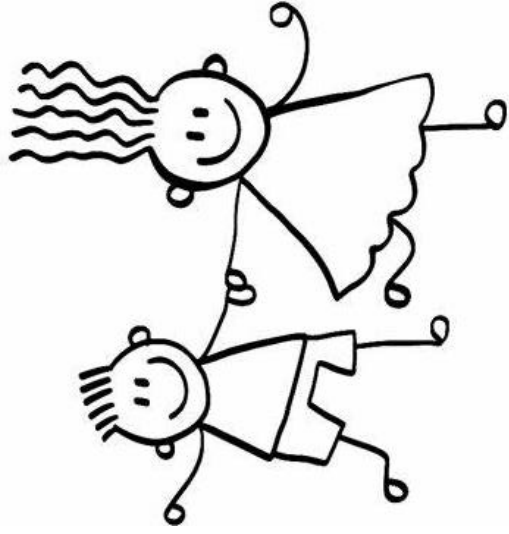

We **had** different books.

We **didn't have** different books.

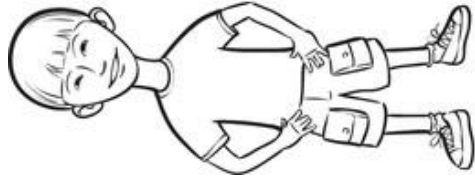

They **have** an important question.

They **don't have** an important question.

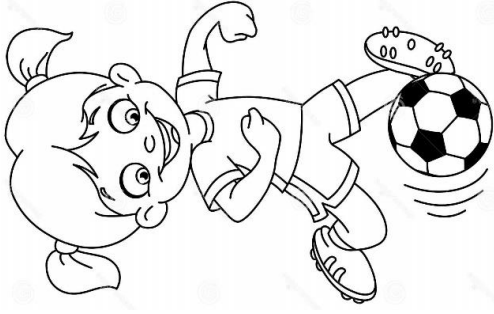
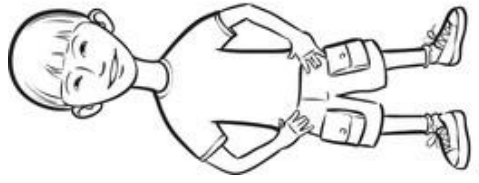

They **had** a game last month.

They **didn't have** a game last month.

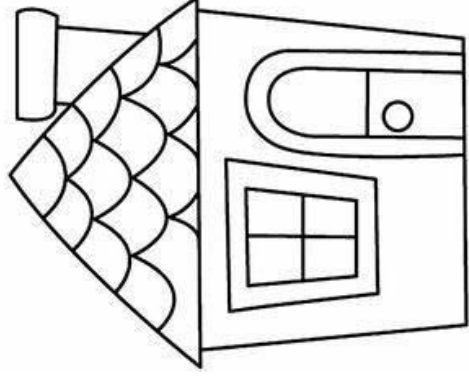
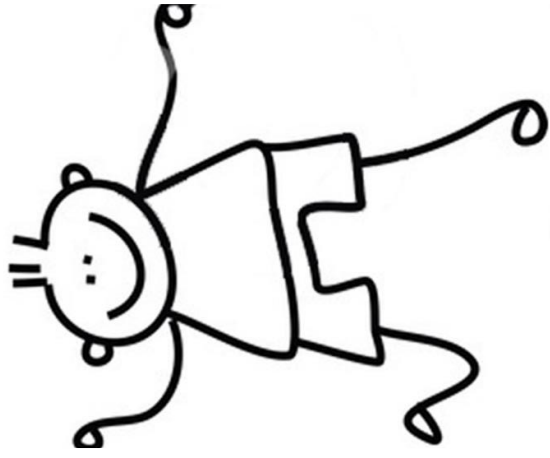

I **am going** home.

I **went** home.

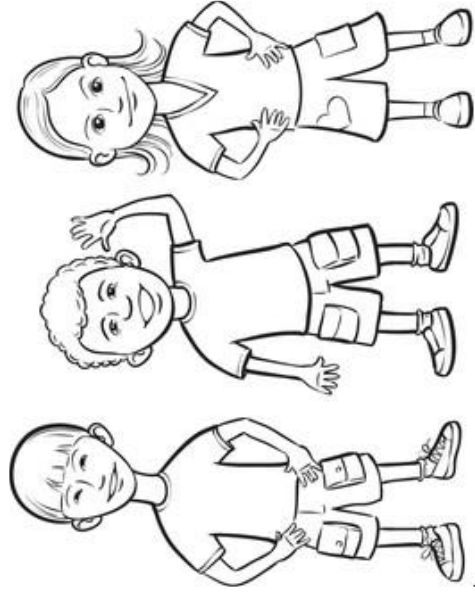
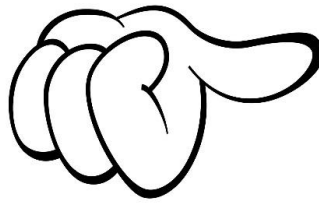
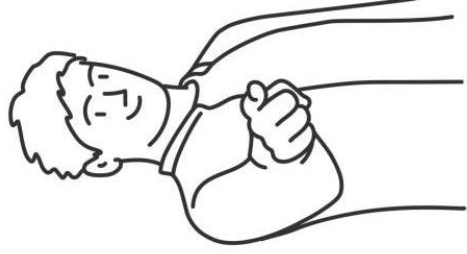

They **are saying** bad things about you.

They **said** bad things about you.

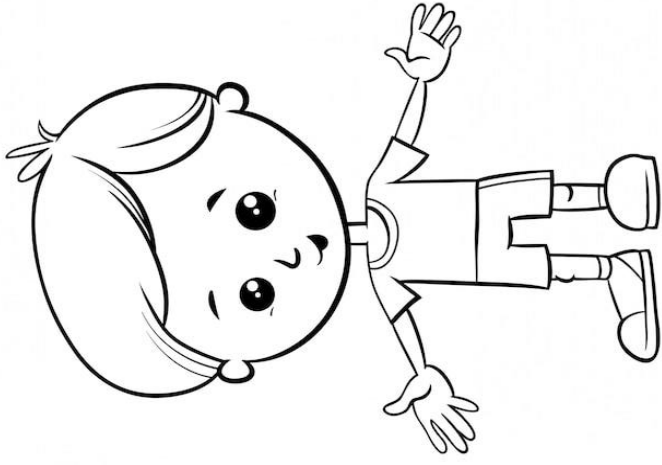

He **makes** good things.

He **made** good things.

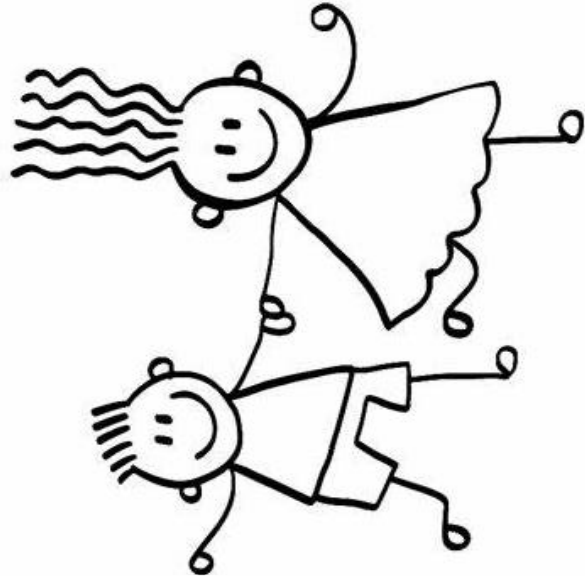

We will **get** new things this year.

We **got** new things last year.

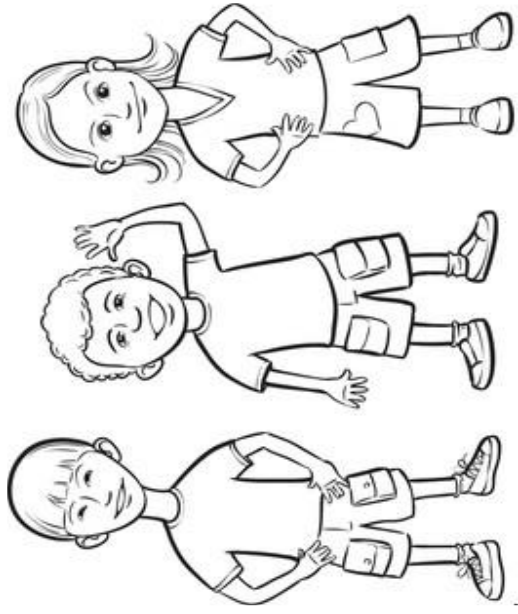

They **think** that you are great.

They **thought** that you were great.

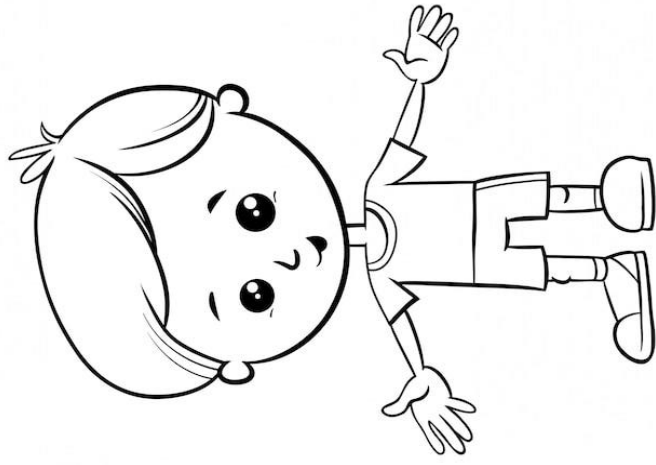

He **can** speak English.

He **could** speak English.

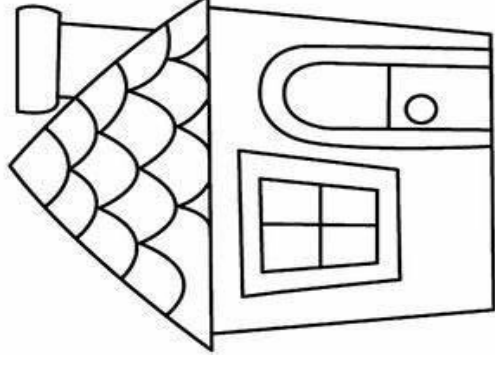
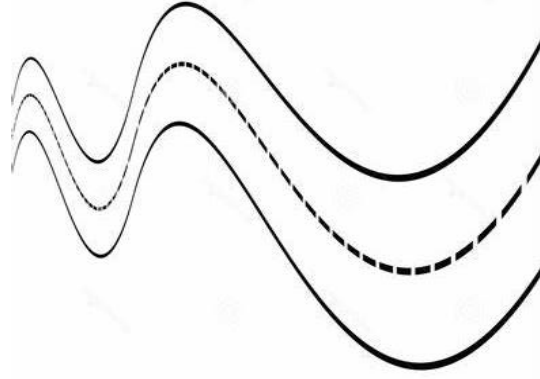
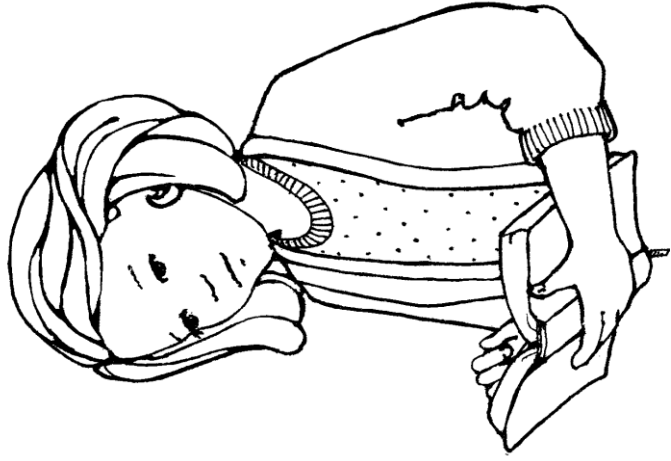

The woman can **see** the way to her house.

The woman **saw** the way to her house.

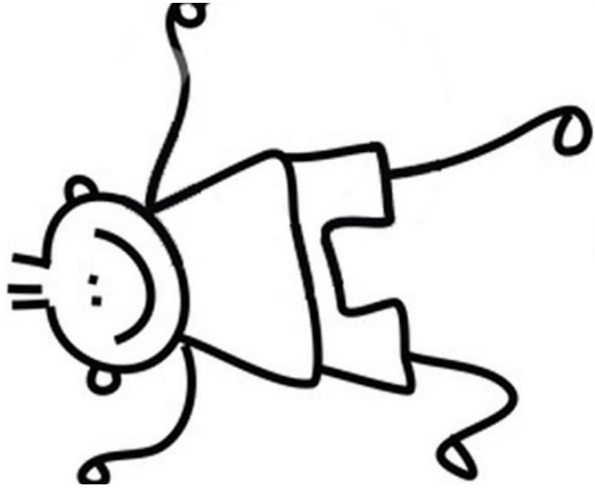

I **know** about the world.

I **knew** about the world.

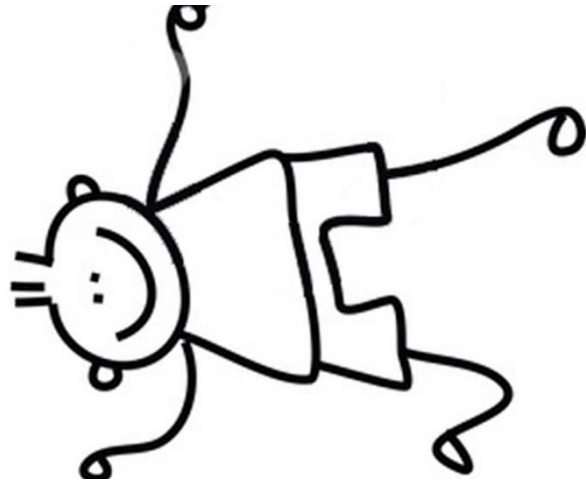

There **will** be a new day.

I **will** be a new man.



She **would** do that.

She **wouldn't** do that.

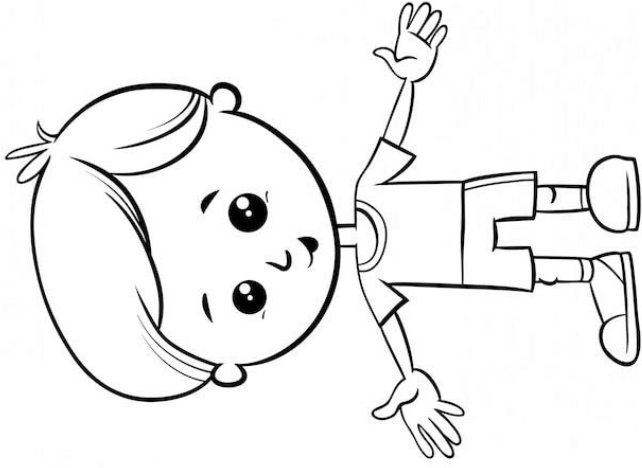

He **comes** late every night.

He **came** late last night.

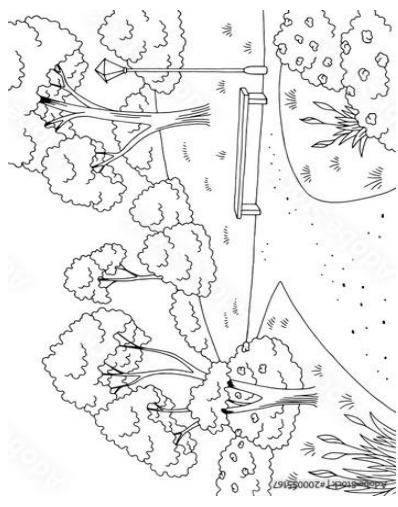
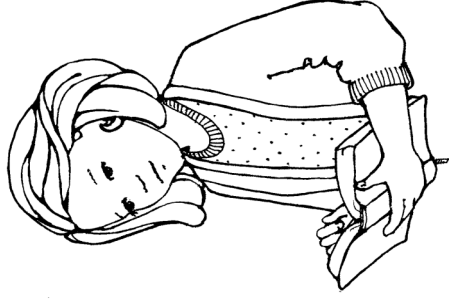
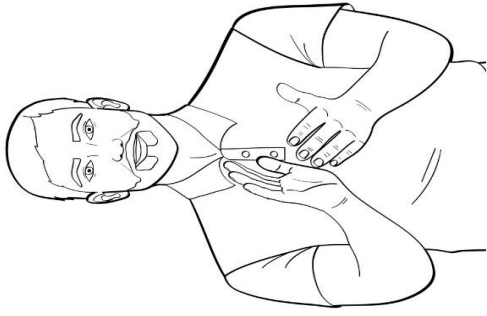
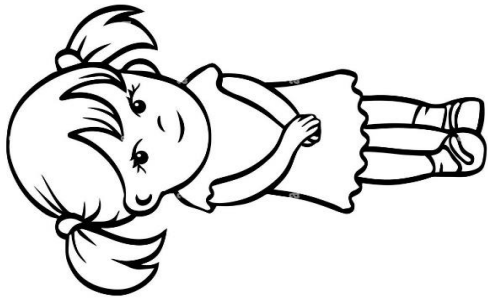

She is **taking** the man and the woman to the big park.

She **took** the man and the woman to the big park.

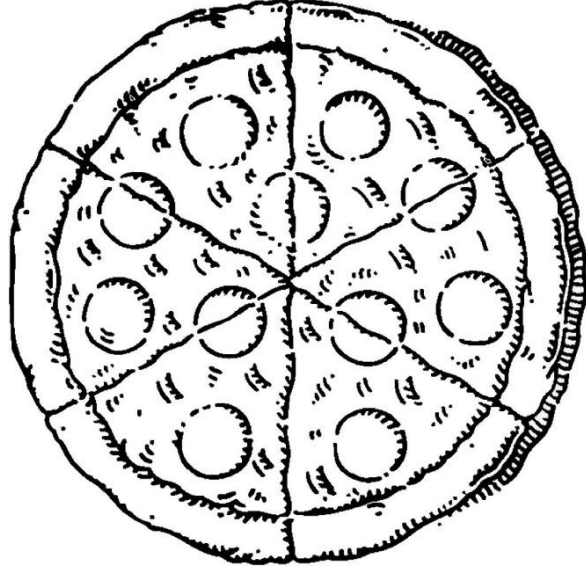
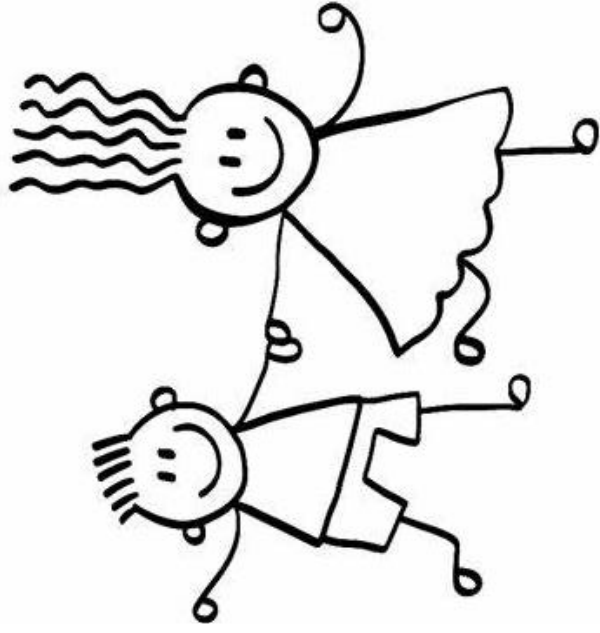

We **want** a big pizza.

We **wanted** a big pizza.

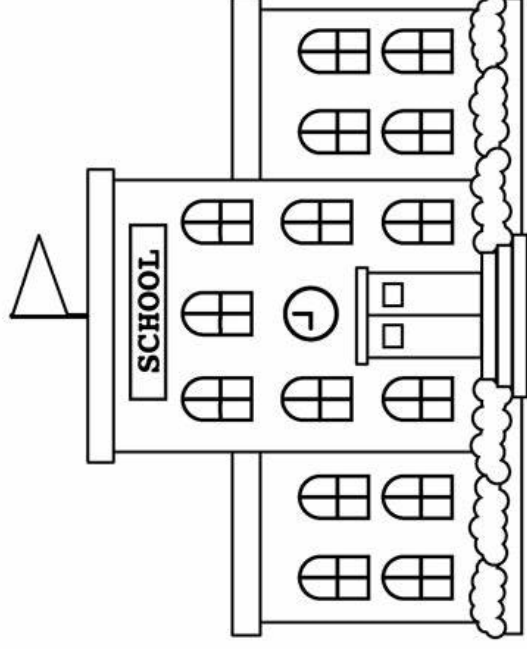
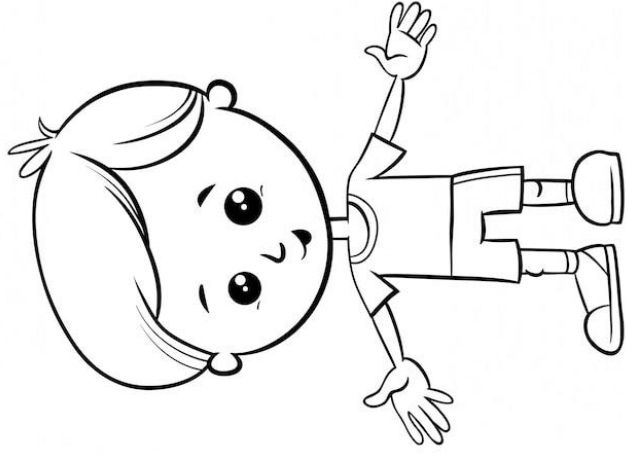

He **could** come to school.

He **couldn't** come to school.

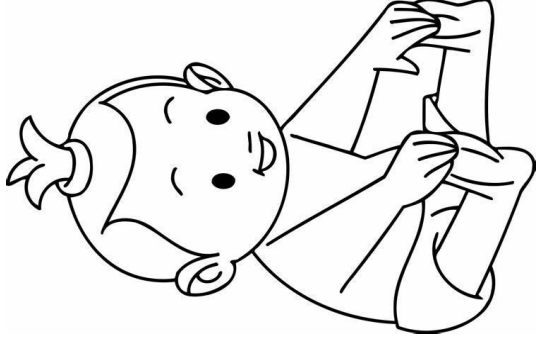
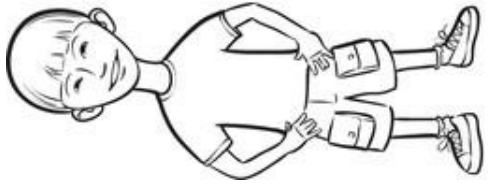

They **are looking** at the child.

They **looked** at the child.

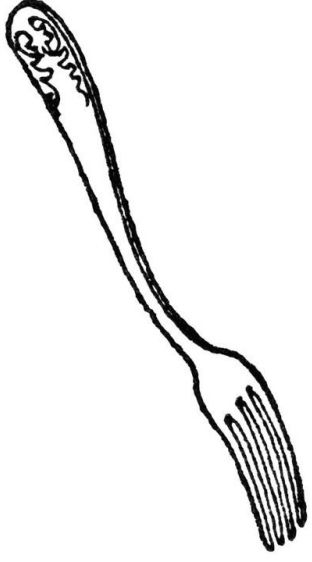
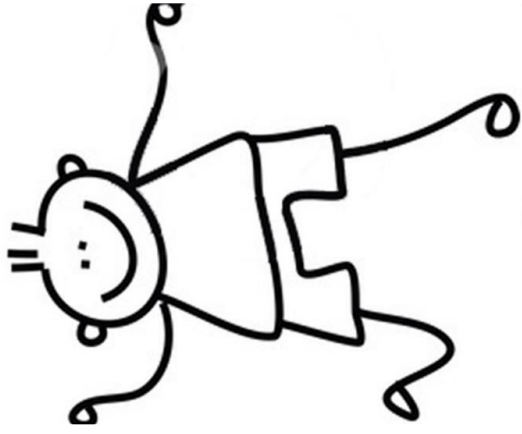

I **use** an old and bad fork every day.

I **used** an old and bad fork.

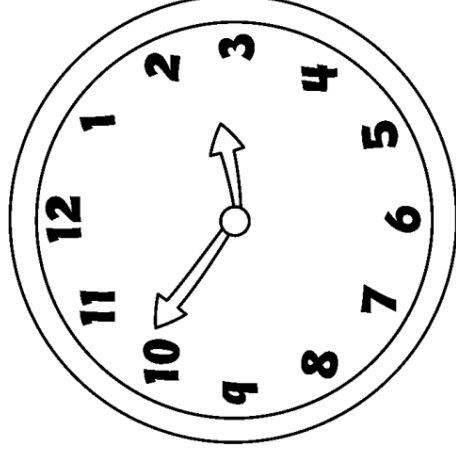
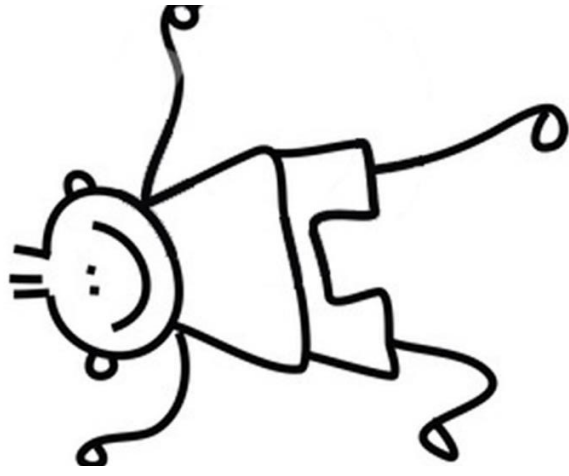

I **tell** stories all the time.

I **told** stories all the time.

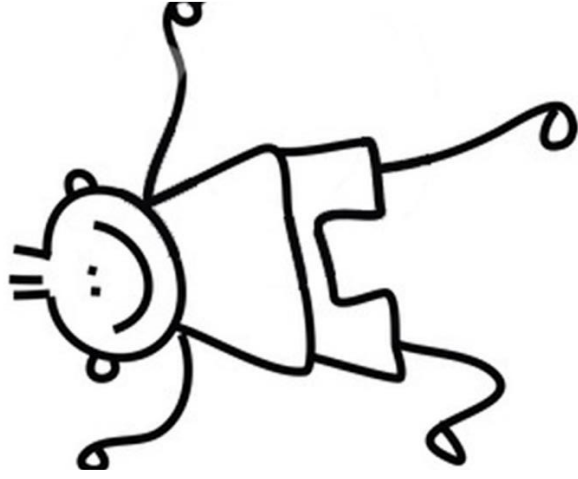

I will **find** the president.

I **found** the president.

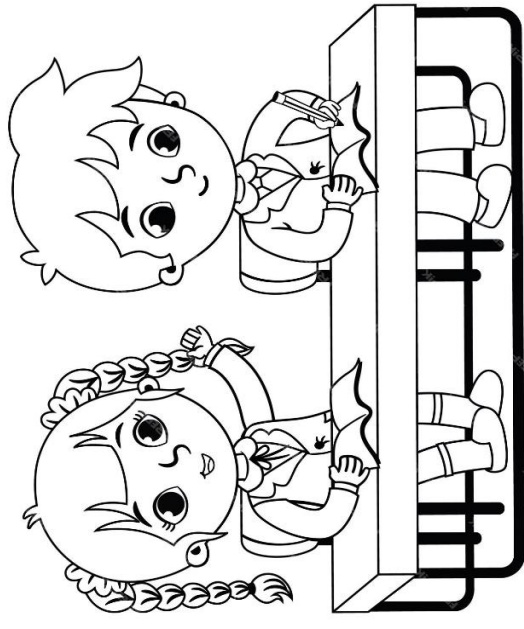
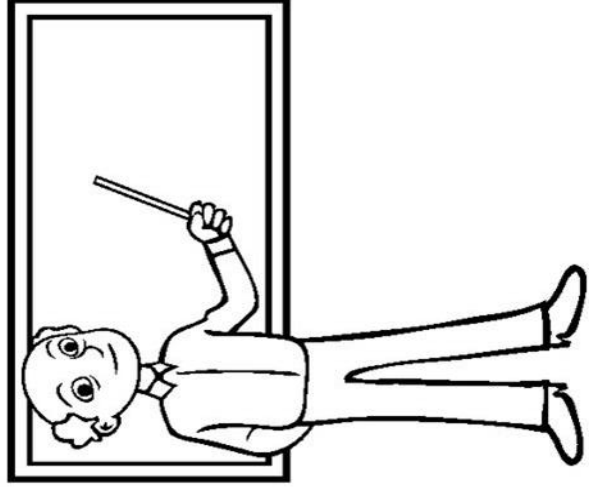

The teacher **is giving** activities to the students.

The teacher **gave** activities to the students.

It **should** be easy.

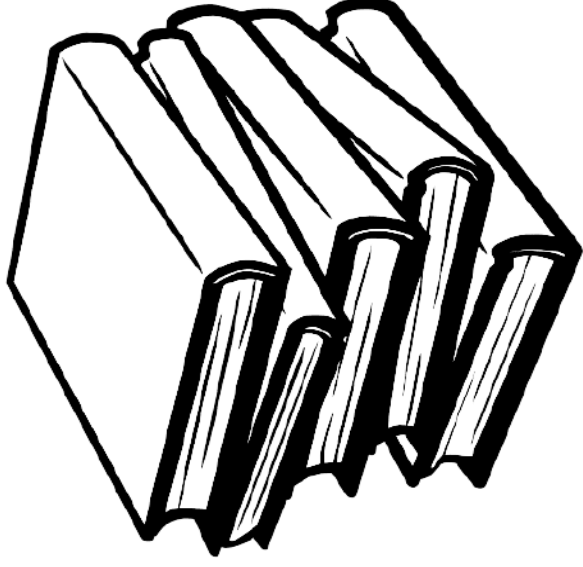

His friend **works** for a book company.

His friend **worked** for a book company.

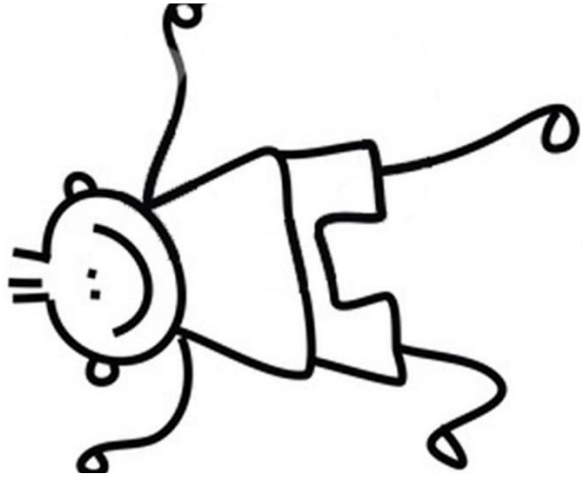

I always **try** to find the best words.

I **tried** to find the best words.

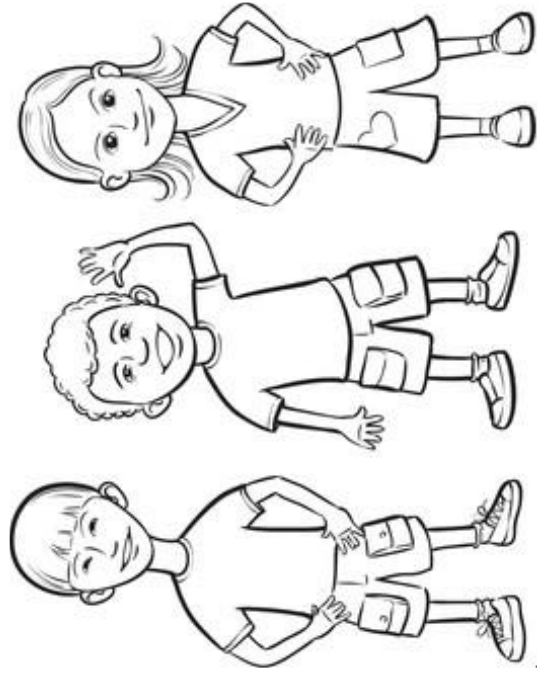

They **let** him win.

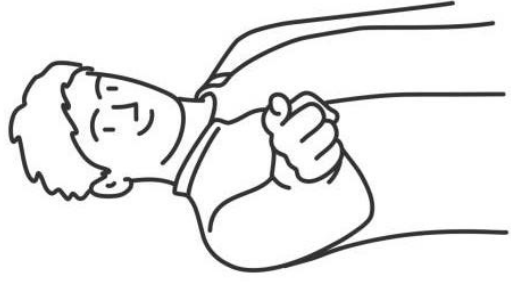

Did you **call** her late at night?

I **called** her last night.



This **may** help you!

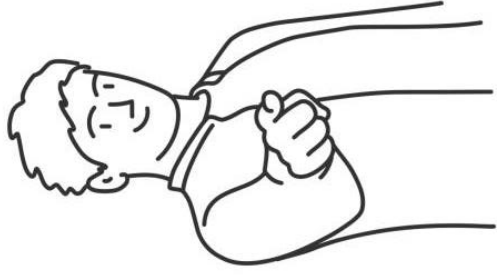

What do you **mean**?

I **meant** to say yes.



How **are** you **feeling**?

He **felt** sick last week.

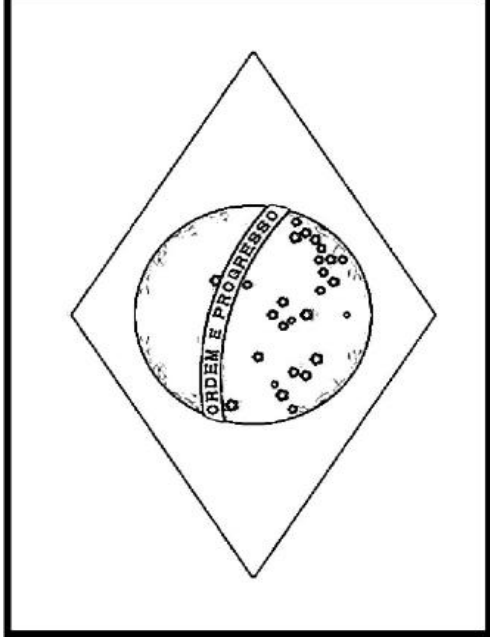
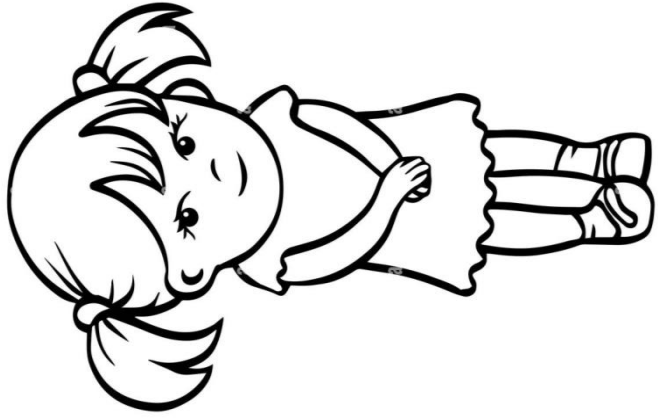

She **asked** me about Brazilian history.

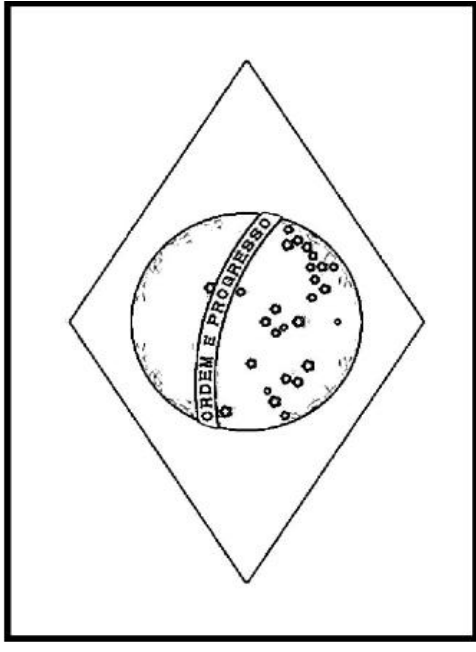
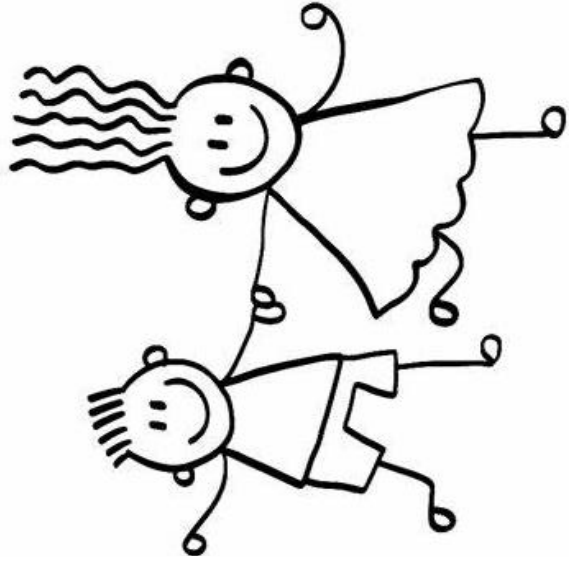

We **were** just **talking** about Brazil.

We **talked** about Brazil.

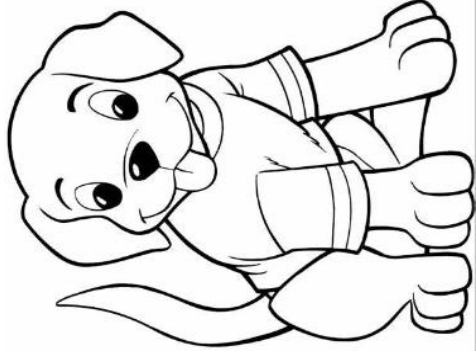
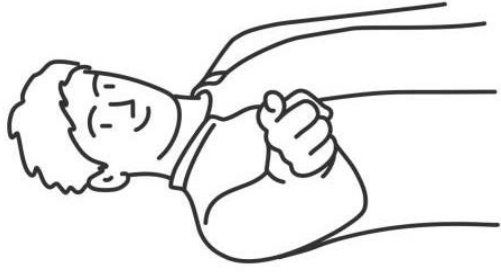

Can you **keep** the dog outside, please?

You **kept** the dog outside.

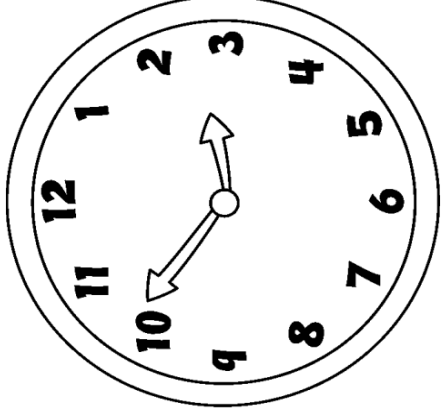
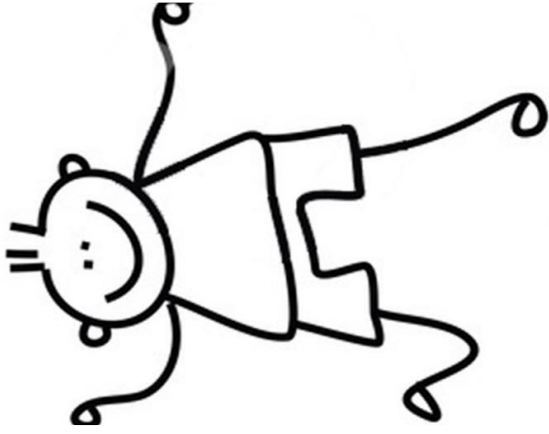

I'll be **leaving** at five o'clock tomorrow.

I **left** at five o'clock yesterday.

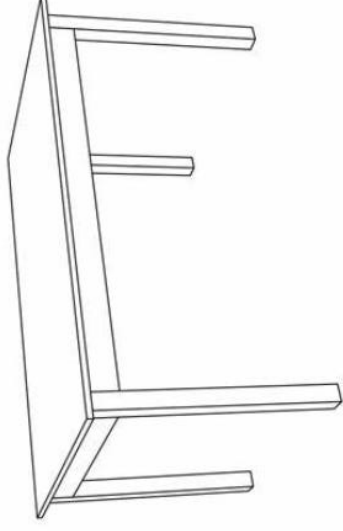
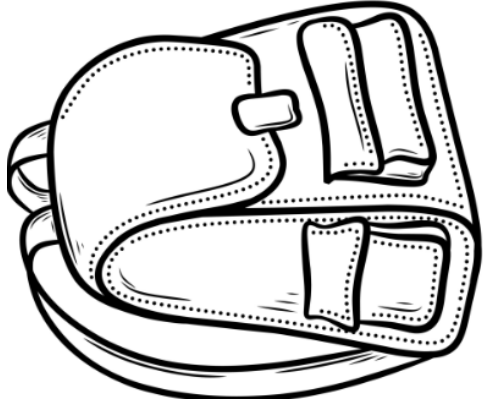
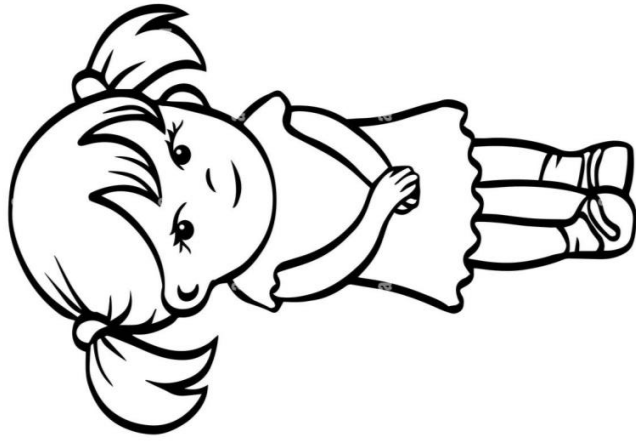

She **put** her bag on the table.



She **likes** your eyes.

She **liked** your eyes.

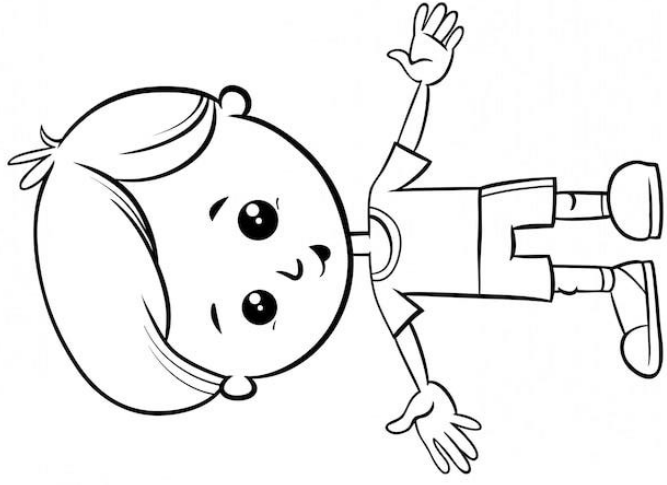

He **helps** his mother.

He **helped** his mother.

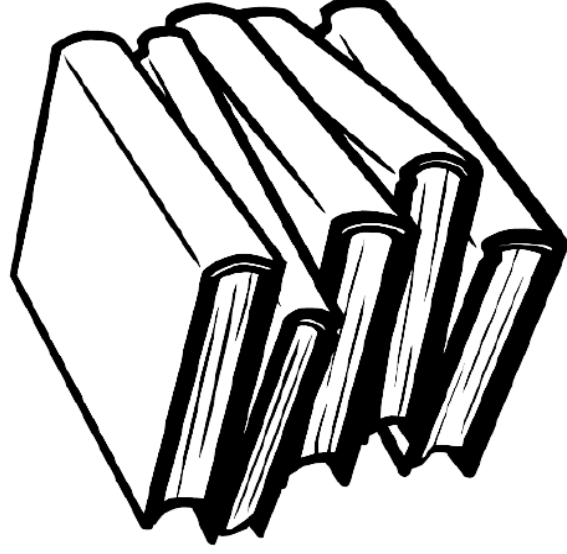
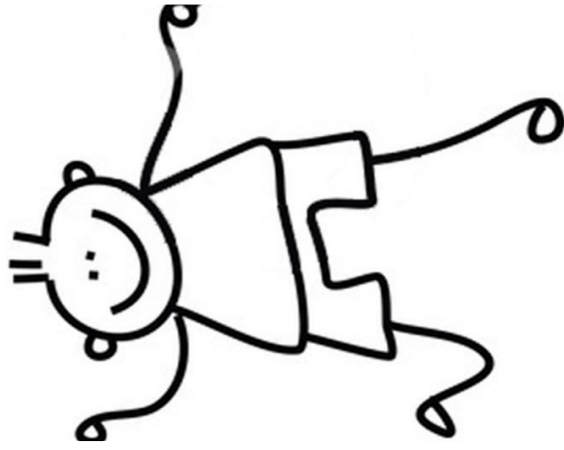

I **start** reading a book.

I **started** reading a book yesterday.

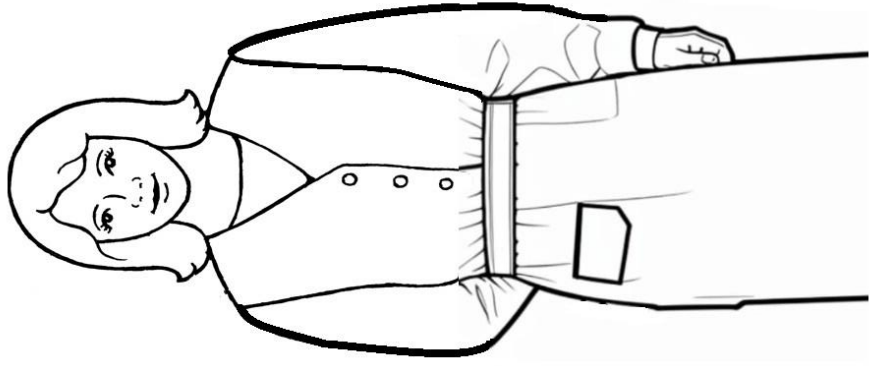

This **is** Katherine

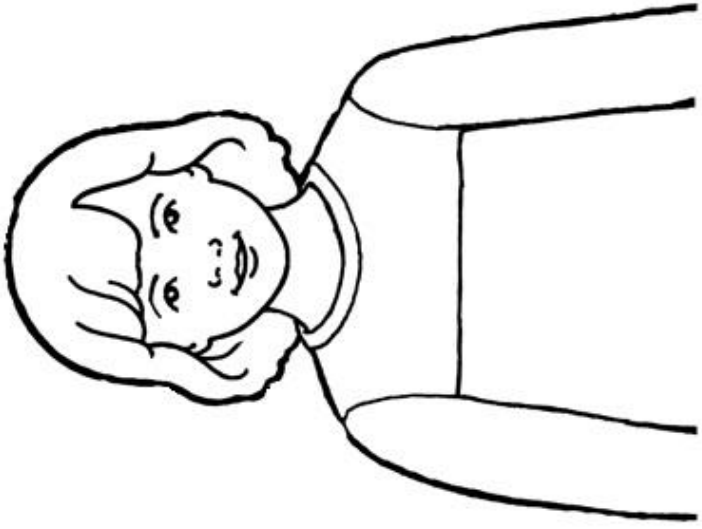

This **is** Audrey

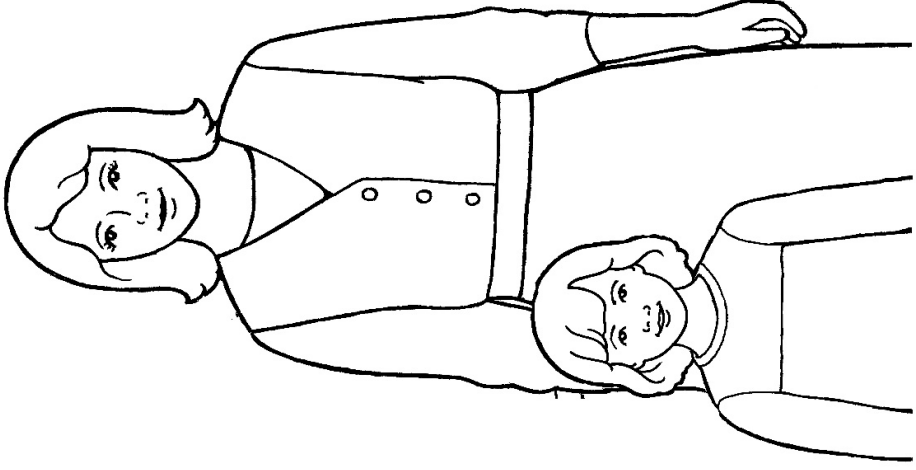

Katherine **is** Audrey's mom.

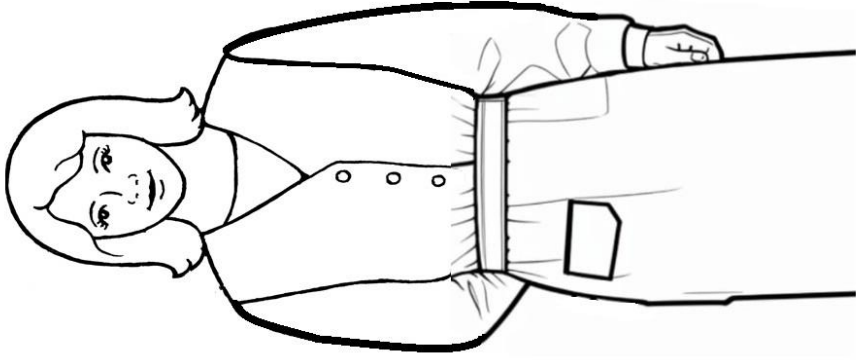

Katherine: I **like** to **read** books.

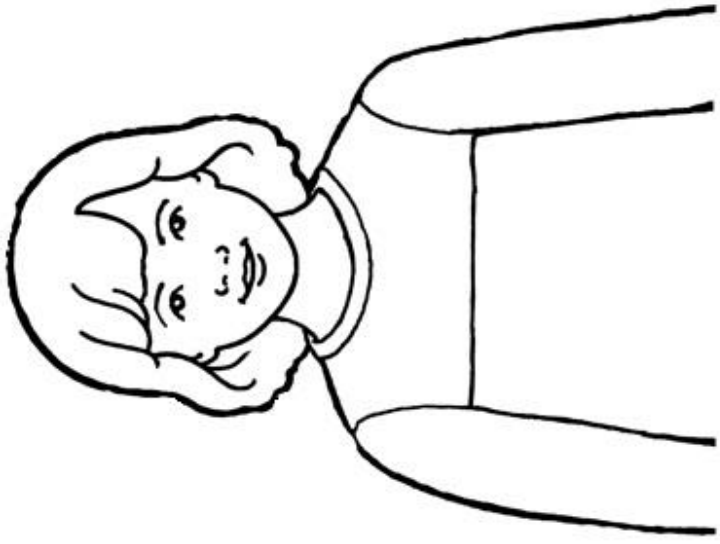

Audrey: I **forgot** my notebook.

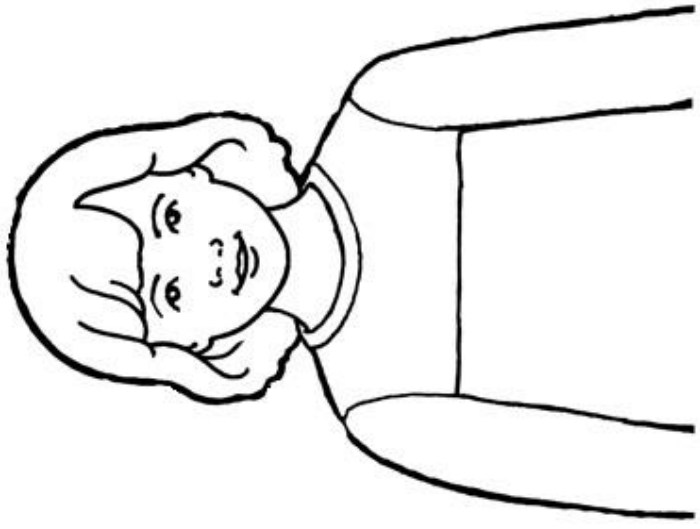

Audrey: I **forgot** my eraser.

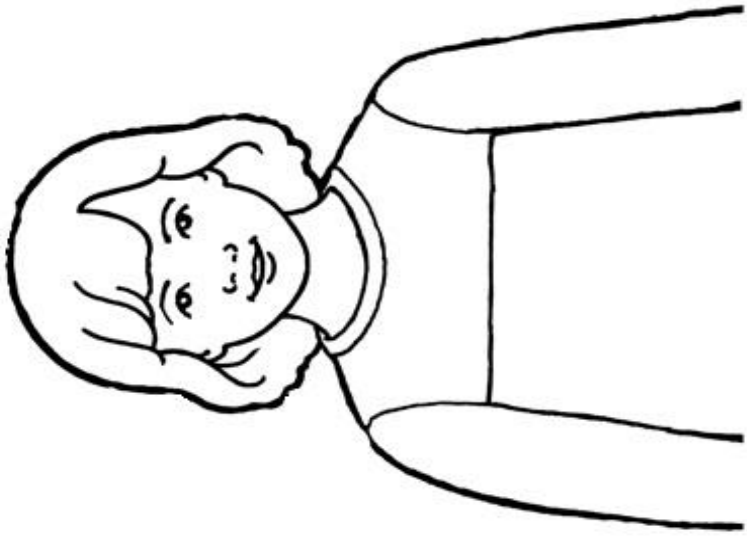

I **forgot** my pencil, **said** Audrey.

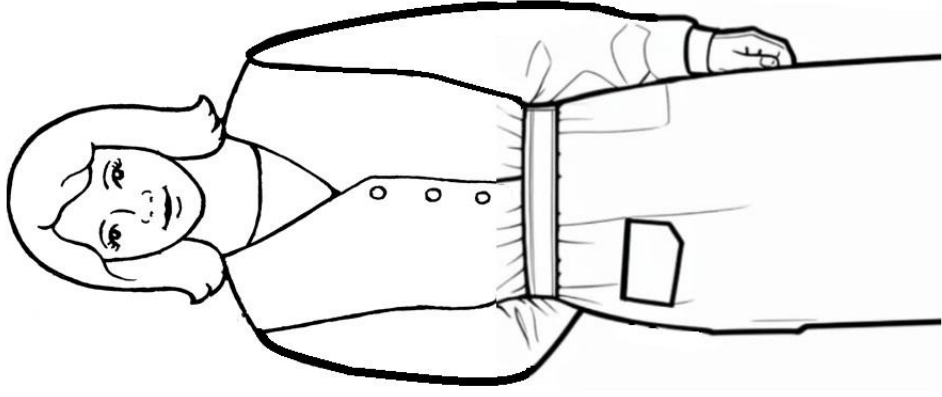

I am here, said Katherine.

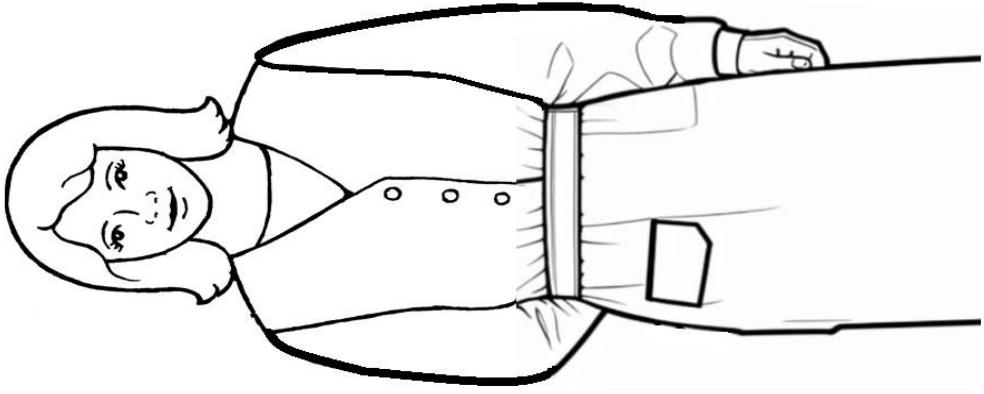

Katherine: How was school today, Audrey?

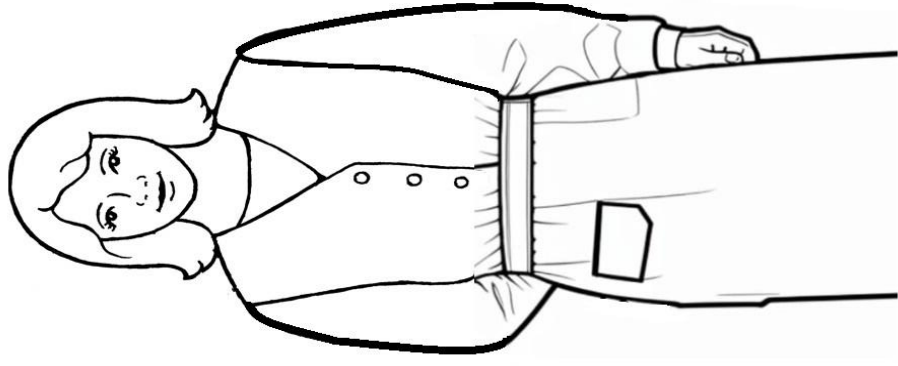

Audrey: It was good, Mom, but we have so
much homework!

How are you?

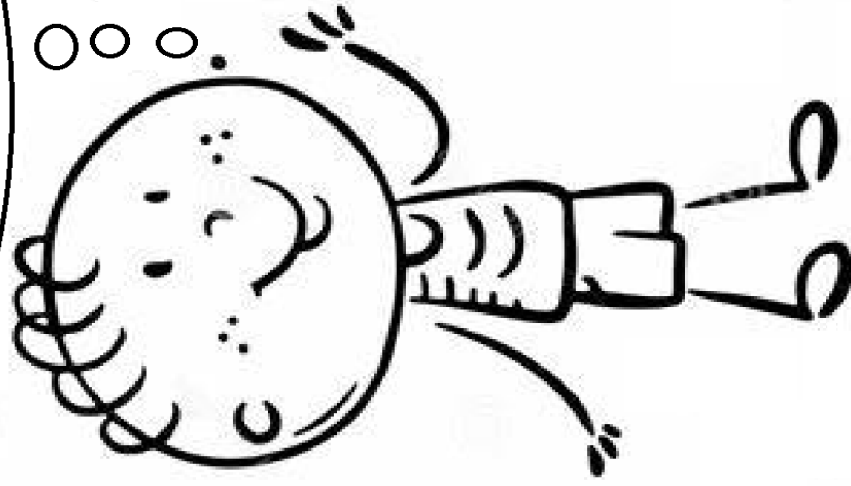

I am fine
thanks, and
you?

